

**POTTERTON**

PrimaF

**30F, 40F, 50F, 60F, 80F & 100F fanned
balanced flue gas fired boilers**

THIS APPLIANCE IS FOR USE WITH NATURAL GAS (G20) ONLY



Installation and Servicing Instructions

LEAVE THESE INSTRUCTIONS ADJACENT TO THE GAS METER.



SAFETY, PERFORMANCE & QUALITY



Prima F boilers have been assessed by a Government appointed Notified Body and shown to meet the 'Essential Requirements' of the European Gas Appliance Directive.

The Directive lays down requirements for the safety and efficiency of the appliance, together with its design, construction, and use of materials. It also requires the production process to be covered by an approved and monitored system of quality assurance.

The BSI kitemark remains on the product, demonstrating continued conformity with the relevant BSI safety, performance and quality (BS.5750) standards.

POTTERTON PRIMA 30F G.C. No. 41.607.01
POTTERTON PRIMA 40F G.C. No. 41.607.02
POTTERTON PRIMA 50F G.C. No. 41.607.03

POTTERTON PRIMA 60F G.C. No. 41.607.04
POTTERTON PRIMA 80F G.C. No. 41.607.32
POTTERTON PRIMA 100F G.C. No. 41.607.33

CONTENTS

General	Page No. 2
Optional Extras	Page No. 2
Accessories	Page No. 3
Installation Data	Page No. 3
Boiler Dimensions	Page No. 3
Site Requirements	Page No. 3
Technical Data	Page No. 6
Installation Instructions	Page No. 11
Commissioning	Page No. 18
Health and Safety Information	Back Page
Control Systems, Pipework and Wiring Guide	Supplied in Literature Pack
User's Instructions	

IMPORTANT

The appliance must be installed and serviced by a competent person as stated in the Gas Safety (Installation and Use) Regulations 1984.

Prima F boilers (formerly known as 'Profile Prima') are certified by BSI for safety, it is therefore important that no external control devices (e.g. flue dampers, economisers, etc.) be directly connected to these appliances unless covered by these installation instructions or otherwise recommended in writing. Any direct connection of a control device not approved by Potterton could invalidate the BSI certificate and the normal warranty.

GENERAL

Prima F boilers are fully automatically controlled, wall mounted, fan powered, balanced flue appliances, using a cast iron heat exchanger and are available in six outputs ranging from 5.86-29.3 kW (20,000-100,000 Btu/h).

The boilers which are designed to provide domestic hot water and/or central heating must be used on INDIRECT FULLY PUMPED systems only, which may be sealed or open vented.

The boilers can be supplied with either of the following types of flue system:

Standard horizontal flue system which is suitable for a wall thickness of 100mm (4in) to 510 (20in).

PRIMA 100F MODEL ONLY

1 metre horizontal flue system which provides a maximum flue length of 955mm (37in).

Vertical Flue system which allows the flue to pass through a flat roof and terminate at a maximum height of 980mm (38in) measured from the top of boiler case.

PRIMA 30F, 40F, 50F, 60F & 80F Models only
2 metre horizontal flue system which provides a maximum flue length of 1955mm (77in).

Vertical flue system which allows the flue to pass through a flat roof and terminate at a maximum height of 1980mm (78in) measured from the top of boiler case.

OPTIONAL EXTRAS

The following are kits available as optional extras:-

Internal Fitment Kit, which is suitable for a maximum wall thickness of 510mm (20 in.) is to be used where access to the outside wall is impracticable.

Pump Cover Kits located on top of the boiler and designed to conceal the pump, and/or any motorised valves installed above the boiler. (Note: Pump cannot be fitted above the boiler if the vertical flue kit is used).

Terminal Wall Plate, where necessary can be fitted to the outside wall face to improve the appearance, after making good around the terminal.

Terminal Guard, to be used when the terminal is fitted less than 2m above a balcony, above ground or above a flat roof to which people have access.

45° and 90° Flue Bend Kits, giving greater flueing flexibility (Prima 30F to 60F only).

Vertex Flue Kit, giving greater vertical flueing flexibility through a roof space (Prima 30F to 60F only).

Full fitting instructions are provided with each kit.

SEE PAGE 10 FOR PART Nos. OF FLUE KITS AND OPTIONS.

ACCESSORIES

The following Potterton Myson controls are recommended for use with your boiler:-

Electronic Programmer EP2001, EP3001, or EP6000

Cylinder Thermostat PTT2 or PTT100

Room Thermostat PRT2 or PRT100

Frost Thermostat PRT100 FR

Motorised Zone Valve MSV222 or MSV228

Motorised Diverter Valve MSV322

Thermostatic Radiator Valve

Data Sheets describing these products are available on request.

INSTALLATION DATA

The installation of the boiler must be in accordance with the latest relevant requirements of the Gas Safety (Installation and Use) Regulations, local building regulations, IEE Wiring Regulations and the Byelaws of the Local Water Undertaking.

Detailed recommendations are contained in the following British Standards and Codes of Practice.

BS6798, BS5440 Part1

BS5440 Part 2 BS5449 Part1

BS5546 BS4814. BS6891.

BUILDING REGULATIONS.

MODEL WATER BYELAWS.

BRITISH GAS PUBLICATION DM2.

GAS SAFETY (INSTALLATION AND USE) REGULATIONS.

BUILDING STANDARDS (SCOTLAND)

REGULATIONS.

BOILER DIMENSIONS

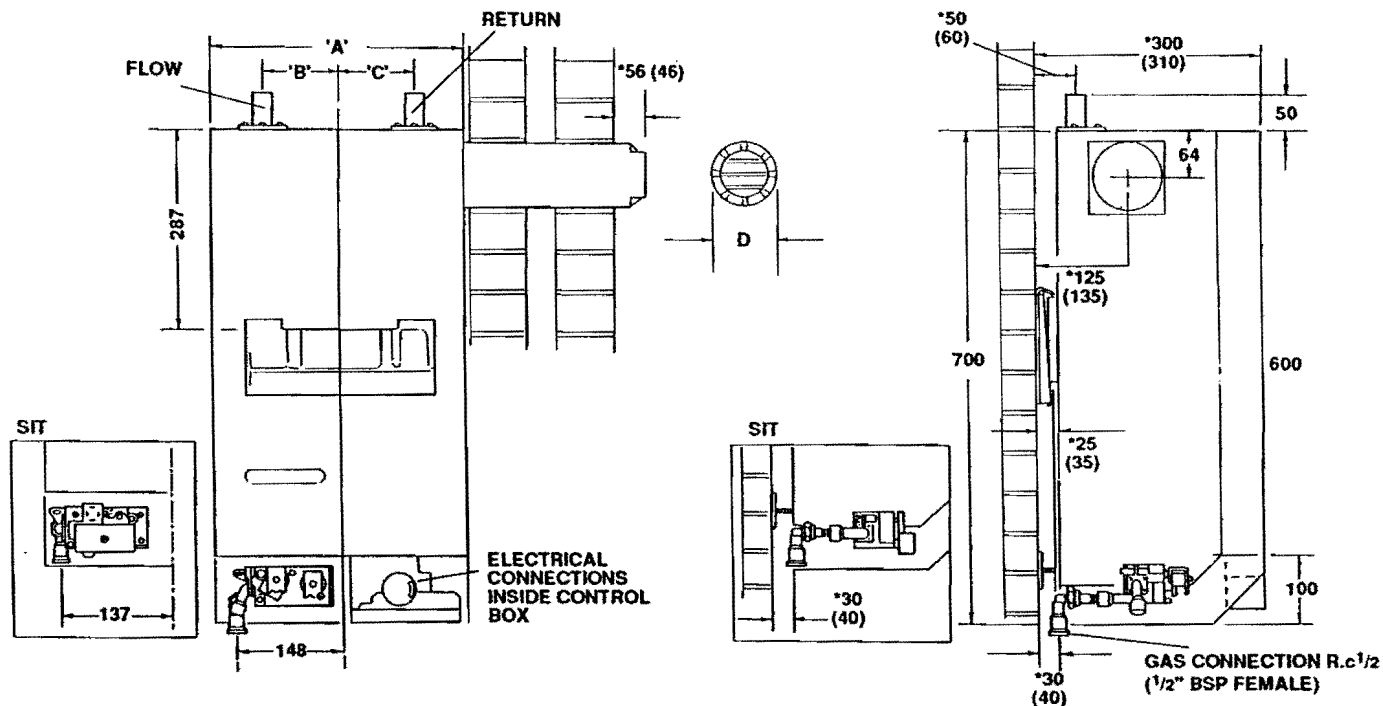

FIG. 1

Boiler	30F	40F	50F	60F	80F	100F
Dimension 'A'	350	350	350	350	425	425
(mm) 'B'	110	110	110	110	150	150
'C'	103	103	103	103	143	143
'D'	87	87	87	107	107	107
Flow/Return Connections	22mm Copper	22mm Copper	22mm Copper	22mm Copper	28mm Copper	28mm Copper

*NOTE:
IF PIPEWORK IS TO BE RUN DOWN THE BACK OF THE BOILER THE NORMAL CLEARANCE OF 25mm BETWEEN THE REAR OF THE BOILER AND WALL CAN BE INCREASED TO 35mm IF DESIRED BY INVERTING THE BOILER MOUNTING PLATE DURING INSTALLATION

(Dimensions in brackets apply when the mounting plate is inverted).

SITE REQUIREMENTS

These boilers are not suitable for external installation and should not be fitted directly above a cooking appliance. The boiler may be installed in any room, although particular attention is drawn to the requirements of the current I.E.E. Wiring Regulations and in Scotland, the electrical provisions of the Building Standards applicable in Scotland with respect to the

installation of the appliance in a room containing a bath or shower.

Where a room-sealed appliance is installed in a room containing a bath or shower, any electrical switch or appliance control, utilising mains electricity should be so situated that it cannot be touched by a person using the bath or shower.

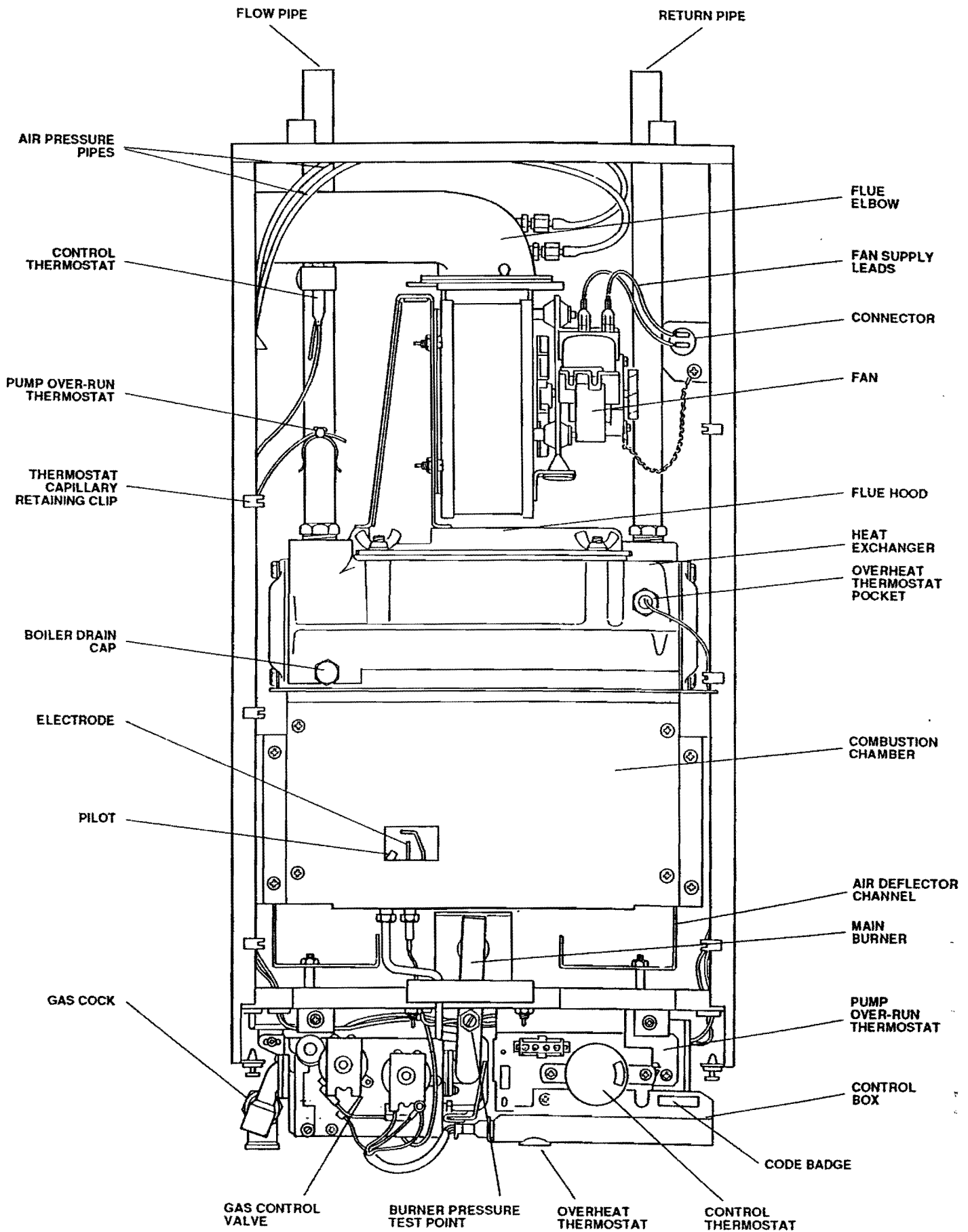

FIG. 2 GENERAL ARRANGEMENT

Where the installation of the boiler will be in an unusual location, special procedures may be necessary and BS 6798 gives detailed guidance on this aspect.

Ensure that the gas supply pipe and meter are large enough for this appliance and any others that may be run off the same meter. Reference should be made to BS6891

Boiler Mounting Surface

The boiler must be mounted on a flat wall, which may be of combustible material and must be sufficiently robust to take the weight of the boiler. The requirements of the local authorities and the Building Regulations must be adhered to.

IMPORTANT NOTICE: TIMBER FRAMED HOUSES

If the appliance is to be fitted in a timber framed building, it should be fitted in accordance with British Gas Publication DM2 'Guide for Gas Installations in Timber Framed Housing'. If in doubt, advice must be sought from the local Gas Region of British Gas.

Clearances Around the Boiler

The following minimum clearances must be maintained after installation, for correct operation and servicing of the boiler:

610mm (2 ft) at the front of the boiler

5mm (0.2 in) each side of the boiler

50mm (2 in) at the top (measured from the top of the boiler case), except where the optional extra pump cover is to be fitted, when 178mm (7 in) should be allowed.

100mm (4 in) at the bottom of the boiler.

Additional clearances to these are required during installation for lifting the boiler and 127mm (5 in) is required at the top of the boiler for access to the pipe connections.

Ventilation

If the boiler is to be installed in a confined space such as a cupboard, the space will need ventilating. Openings must be provided at the top and bottom of the cupboard each of which should have a free area as shown in TABLE 1. Further details for installation of a boiler within a compartment are given in BS 6798.

TABLE 1

PRIMA	AIR VENT AREAS	
	in ²	cm ²
30F	16	103
40F	21	135
50F	26	170
60F	32	206
80F	43	277
100F	54	349

If the openings draw air from outside the building the free areas may be halved. Refer to BS 5440 Part 2 for further guidance.

Balanced Flue Terminal and Ducting

The fresh air inlet and flue ducts can be run from either the left, right, rear or top of the boiler to a miniature terminal on the outside of the building.

The minimum spacings from the terminal to obstructions and ventilation openings are shown in FIG. 3. For information appertaining to horizontal flue lengths reference should be made to FIG. 4.

If a terminal is fitted less than 2m above a balcony, above ground or above a flat roof to which people have access then a suitable terminal guard should be fitted. (P.I.L. No. 205792).

Refer to BS5440 Part 1 for further guidance.

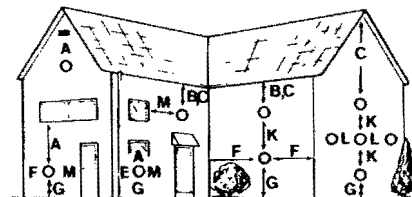

Under Carport.

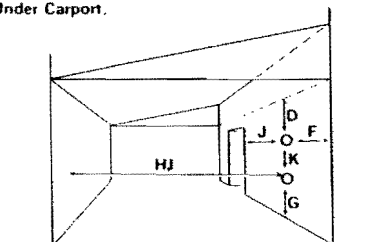

FIG. 3 THE SITING OF BALANCED FLUE TERMINALS

INFORMATION RELATING TO VERTICAL FLUING IS PROVIDED IN THE PACK CONTAINING THE VERTICAL FLUE SYSTEM.

NOTE

Where a flue terminal is fitted less than 1000mm from a plastic or painted gutter or 500mm from painted eaves, an aluminium shield of 1000mm length should be fitted to underside of gutter or eaves.

Any car port or other add-on extension should consist of a roof or a roof and one other wall. If it consists of a roof and two other walls — the installation shall be treated as suspect and further advice sought.

POSITION MINIMUM DISTANCE

POSITION	MINIMUM DISTANCE
A. DIRECTLY BELOW AN OPENABLE WINDOW, AIR VENT, OR ANY OTHER VENTILATION OPENING.	300
B. BELOW GUTTER, DRAIN/SOIL PIPE	25
C. BELOW EAVES	25
D. BELOW A BALCONY OR CAR PORT ROOF	25
E. FROM VERTICAL DRAIN PIPES AND SOIL PIPES	75
F. FROM INTERNAL OR EXTERNAL CORNERS	25
G. ABOVE ADJACENT GROUND OR BALCONY LEVEL	300
H. FROM A SURFACE FACING THE TERMINAL	600
I. FACING TERMINALS	1.200
J. FROM OPENING (DOOR/WINDOW) IN CARPORT INTO DWELLING	1.200
K. VERTICALLY FROM A TERMINAL ON THE SAME WALL	1.500
L. HORIZONTALLY FROM A TERMINAL ON THE SAME WALL	300
M. ADJACENT TO OPENING	150

REAR OR SIDE FLUEING

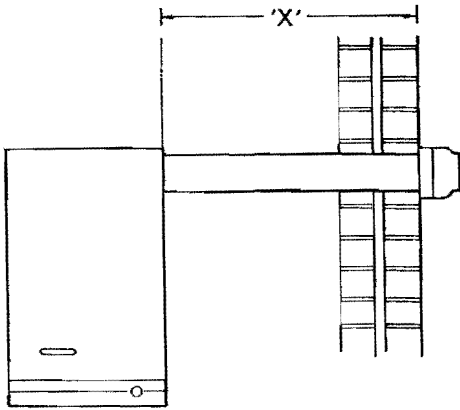

	MAXIMUM LENGTH 'X'
STANDARD FLUE SYSTEM	510mm (20in)
1 METRE RULE SYSTEM 100F MODEL ONLY	955mm (37in)
2 METRE FLUE SYSTEM 30F, 40F, 50F, 60F & 80F MODELS ONLY	1955mm (77in)

FIG. 4 FLUE LENGTHS

ELECTRICITY SUPPLY

A 240 volts~ 50Hz, single phase electricity supply fused to 3 amperes, must be provided in accordance with the latest edition of the I.E.E. Wiring Regulations and any other local regulations that may apply. The current rating of the wiring to the boiler must exceed 3 amperes and have a cross sectional area of at least 0.75mm² in accordance with BS 6500. Table 16.

The supply to the boiler and its associated equipment

should be controlled by an exclusive 3A fused double pole switch (having at least 3mm contact separation in both poles) so that complete isolation from the supply can be achieved to enable servicing work to be carried out in safety.

GAS SUPPLY

A gas supply pressure of 20 mbar is required at the inlet to the appliance. Performance data is based on use of reference gas G20.

TECHNICAL DATA

Maximum working head	30.5m (100ft)
Minimum working head	150mm (6in)
Gas supply pressure	20 mbar
Maximum flow temperature	82°C
Electricity supply	240v-50Hz fused at 3A
Internal Fuse	Type T1A
Power Consumption	80 Watts (excluding pump)
Gas supply connection	Rc. ½ (½in BSP female)

	30F, 40F, 50F & 60F Models	80F & 100F Models
Appliance lift weight (min)	26.0kg (57.3lbs)	33.5kg (73.87lbs)
Appliance weight installed	37.1kg (81.8lbs)	46.4kg (102.3lbs)
Water content	2.0 litre (0.44 gal)	2.4 litre (0.53 gal)
Flow/Return connections	22m copper	28mm copper

BOILER SIZE	INJECTOR SIZE	GAS RATE m ³ /h (ft ³ /h)	INPUT kW(Btu/h)	OUTPUT kW(Btu/h)	BURNER PRESSURE	
					mbar	in wg
30	2.9mm	0.71(25.23)	7.65(26116)	5.86(20000)	3.9	1.6
		0.87(30.61)	9.29(31686)	7.33(25000)	5.9	2.4
		1.03(36.23)	10.99(37500)	8.79(30000)	8.4	3.4
40	3.1mm	1.06(37.40)	11.35(38710)	8.79(30000)	6.5	2.6
		1.21(42.86)	13.00(44360)	10.26(35000)	8.6	3.5
		1.37(48.31)	14.65(50000)	11.72(40000)	11.3	4.5
50	3.5mm	1.39(49.11)	14.90(50826)	11.72(40000)	7.0	2.8
		1.54(54.35)	16.49(56250)	13.19(45000)	8.6	3.5
		1.71(60.39)	18.32(62500)	14.65(50000)	11.0	4.4
60	3.6mm	1.73(61.07)	18.53(63211)	14.65(50000)	10.7	4.3
		1.89(66.84)	20.28(69182)	16.12(55000)	12.8	5.1
		2.05(72.46)	21.98(75000)	17.58(60000)	14.9	6.0
80	4.4mm	2.13(75.19)	22.81(77821)	17.58(60000)	6.6	2.6
		2.43(85.94)	26.07(88945)	20.52(70000)	8.7	3.5
		2.74(96.62)	29.31(100000)	23.45(80000)	11.8	4.7
100	4.7mm	2.78(98.09)	29.75(101523)	23.45(80000)	8.0	3.2
		3.10(109.38)	33.18(113208)	26.37(90000)	9.9	4.0
		3.42(120.77)	36.64(125000)	29.3(100000)	12.2	4.9

CIRCULATION PUMP SELECTION

The resistance through the heat exchanger when operating with a water flow rate producing an 11°C temperature rise at maximum boiler output are shown in TABLE 2. If other controls, such as three-position valves are used in the system, the resistance through them, quoted in their manufacturer's literature must be taken into account. The pump may be fitted on either the flow or return and MUST be wired directly to the boiler terminal block, see FIG. 23. It must be fitted with two isolating valves which are positioned as close to the pump as possible. Closing of any valve must always leave the open vent unobstructed.

TABLE 2

Boiler size	Water Flow Rate		BOILER RESISTANCE	
	Litres/sec	gal. min	kN/m ²	in wg
30F	.19	2.5	1.5	6.0
40F	.25	3.34	3.0	12.0
50F	.32	4.17	4.25	17.0
60F	.38	5.0	6.25	25.0
80F	.51	6.67	7.0	28.0
100F	.64	8.4	11.0	44.0

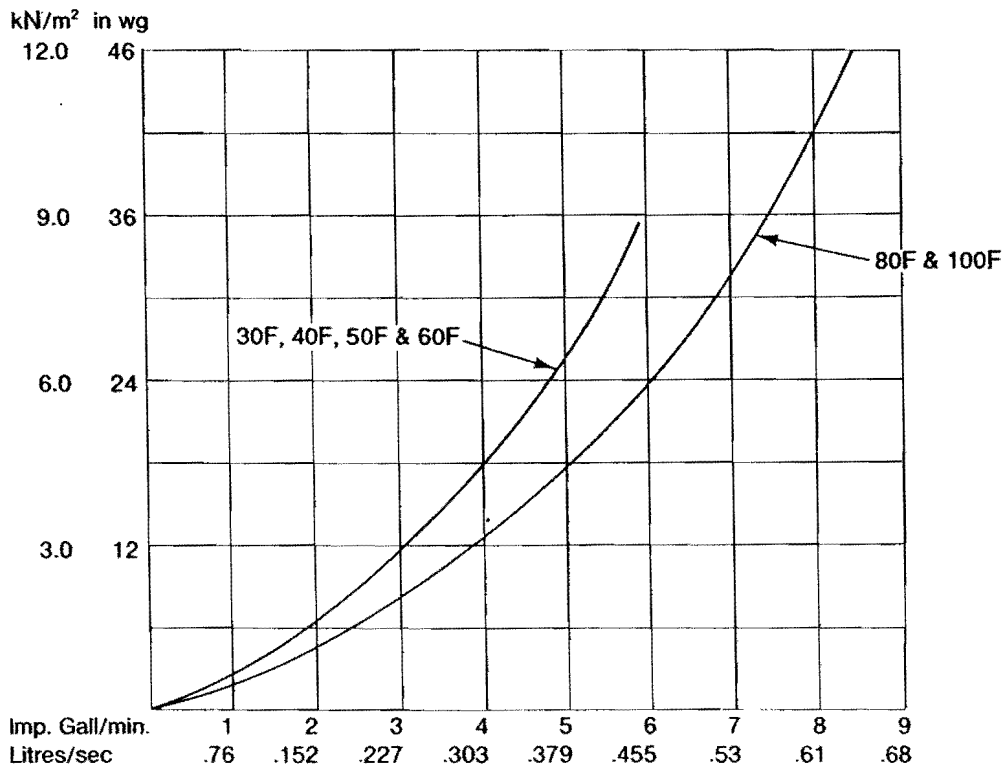

FIG. 5 PRESSURE LOSS ACROSS BOILER

The System

The boiler must be used on INDIRECT FULLY PUMPED systems only, which may be sealed or open vented.

The system should be designed so that the maximum static head does not exceed 30.5m (100ft) and a minimum of 150mm (6in). See FIG 6.

On all systems the pump should be wired to the boiler terminal block, it will then be controlled by the pump over-run thermostat. This will ensure that the pump will continue to run after boiler shut down if the water temperature is high, thus preventing nuisance operation of the overheat thermostat.

It is important that where electrically operated zone valves are used the boiler is wired so it does not cycle when the zone valves are closed. Also, systems fitted with controls that close both hot water and central heating circuits while the boiler is still hot, must be fitted with a by-pass circuit to dissipate the residual heat from within the boiler.

If a three port diverter valve is used as shown in FIGS. 6, 7 a by-pass is not necessary since one circuit is always open.

Where a pair of two port valves are used, a by-pass is necessary. The total length of the by-pass circuit taken from the boiler connections should be greater than 4 metres of 22mm pipe. It should be fitted with a lockshield valve and be adjusted to maintain a minimum flow through the boiler of 4.5 litres/min (1 gal/min) see FIGS 6, 7.

Systems fitted with controls which allow the boiler to operate when both the hot water and central heating circuits are closed i.e. mechanically operated thermostatic control valves, must be fitted with a by-pass circuit capable of:-

1. Dissipating a minimum of 1kW (3400 Btu/h).
2. Maintaining a minimum water flow through the boiler of 9 litres/min (2 gal/min).

A suggested method of meeting these requirements by using a bathroom radiator fitted with two lockshield valves is shown in FIGS. 6, 7.

Additional system information can be found in the Control Systems, Pipework and Wiring Guide.

Drain off taps should be fitted in the pipework close to the boiler and in the low points of the system.

NOTE

Although the system can be emptied using the drain off taps installed in the pipework around the system, to empty the boiler it is necessary to remove the drain off cap positioned within the boiler case. See FIG. 2.

SEALED SYSTEMS

Installation

The installation must comply with the requirements of BS 6798 1987 and BS 5449 Part 1. The B.G. publication "British Gas Specification for Domestic Wet Central Heating Systems" should also be consulted.

Safety Valve

A non-adjustable spring-loaded safety valve, preset to operate at 3 bar (45lbf/in²) shall be used. It must comply with BS 6759 Part 1 and include a manual testing device. It shall be positioned in the flow pipe either horizontally or vertically upwards and close to the boiler. No shut-off valves are to be placed between the boiler and the safety valve. The valve should be installed into a discharge pipe which permits the safe discharge of steam and hot water such that no hazard to persons or damage to electrical components is caused.

Pressure Gauge

A pressure gauge incorporating a fill pressure indicator, covering the range 0-4 bar (60lbf/in²) shall be fitted to the system. It should be connected to the system, preferably at the same point as the expansion vessel. Its location should be visible from the filling point.

Expansion Vessel

A diaphragm type expansion vessel to BS4814 Part 1 shall be fitted close to the inlet side of the pump. The connecting pipework should not be less than 15mm (1/2in nominal). Pipework connecting the expansion vessel should not incorporate valves of any sort. Methods of supporting the vessel are supplied by the manufacturer. The nitrogen or air charge pressure of the expansion vessel shall not be less than the hydrostatic head (height of the top point of the system above the expansion vessel). To size the expansion vessel it is first necessary to calculate the volume of water in the system in litres. The following volumes may be used as a conservative guide to calculating the system volume.

Boiler Heat Exchanger:	6.5 litres
Small Bore Pipework:	1 litre per kW of system output
Micro Bore Pipework:	7 litres
Steel Panel Radiators:	8 litres per kW of system output
Low Water Capacity Radiators:	2 litres per kW of system output
Hot water Cylinder:	2 litres

If the system is extended, the expansion vessel volume may have to be increased unless previous provision has been made for the extension. Where a vessel of the calculated size is not available, the next available larger size should be used.

The boiler flow temperature is controlled at approximately 82°C.

The vessel size can now be determined from the following table where V= System volume in litres.

Vessel Charge Pressure(bar)	0.5	1.0
Initial System Pressure (bar)	1.0	1.0
Expansion Vessel Volume (litres)	$V \times 0.11$	$V \times 0.087$

Cylinder

The hot water cylinder must be an indirect coil type or a direct cylinder fitted with an immersion calorifier suitable for operating at a gauge pressure of 0.3 bar (5lbf/in²) in excess of safety valve setting. Single feed indirect cylinders are not suitable for sealed systems.

Method of Make-Up

Provision shall be made for replacing water loss from the system either:—

- i) from a make-up vessel or tank mounted in a position higher than the top point of the system, and connected through a non-return valve to the system on the return side of hot water cylinder or the return side of all heat emitters.
- or
- ii) where access to a make-up vessel would be difficult by using the mains top up method or a remote automatic pressurisation and make-up unit as illustrated in FIG. 7 METHODS 1 and 2.

Mains Connection

There shall be no connection to the mains water supply or to the water storage tank which supplies domestic water even through a non-return valve, without the approval of the local Water Authority.

Filling Point

The system shall be fitted with a filling point at low level which incorporates a stop valve to BS1010 and a double check valve (approved by the National Water Council) to be fitted in this order from the system mains, Refer to FIG. 7. Method 1.

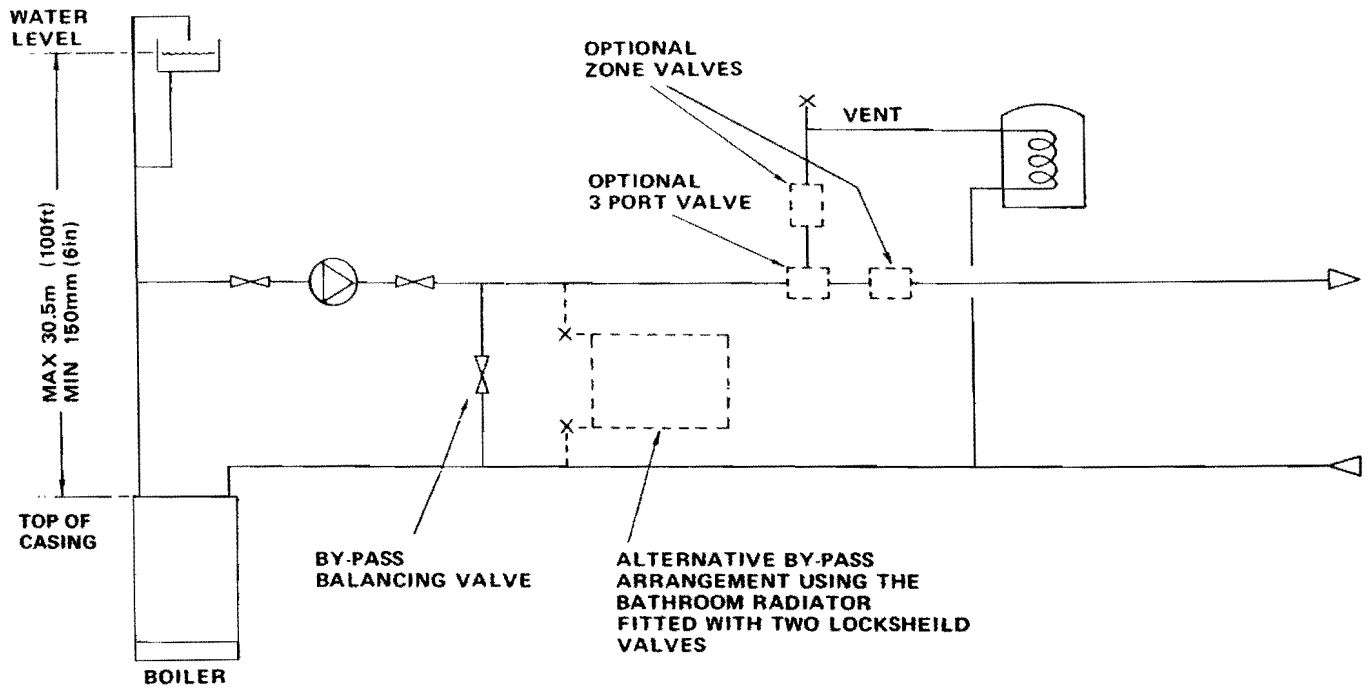
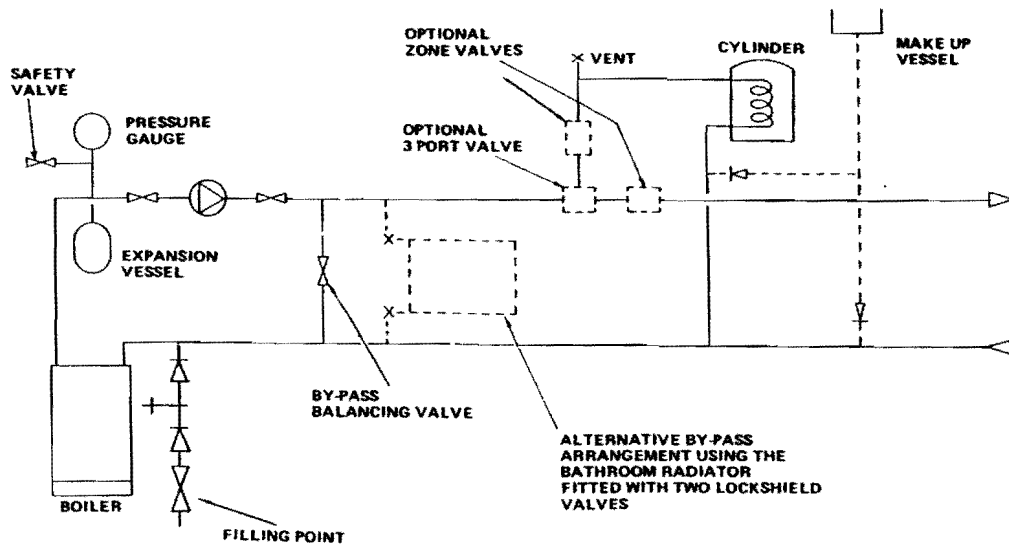

FIG. 6 OPEN VENTED FULLY PUMPED SYSTEM FITTED WITH A COMBINED FEED AND VENT



Two methods of filling a sealed water system

**METHOD 1
MAINS TOPPING-UP
METHOD**

NOTE: This method of filling a sealed system may only be used if acceptable to the Local Water Undertaking

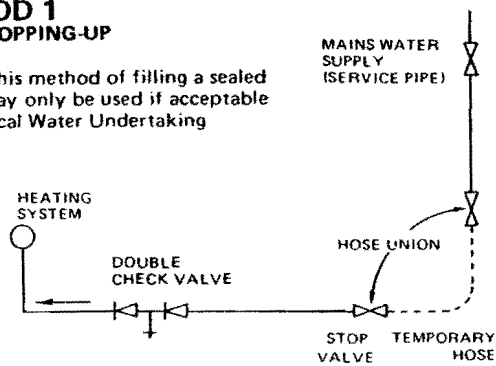

**METHOD 2
CISTERN FILLING METHOD**

NOTE: Cistern to be supplied through a temporary connection from a service pipe or cold water distributing pipe

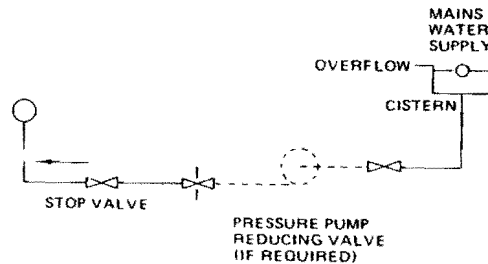

FIG 7. FULLY PUMPED SEALED SYSTEM

FLUE KITS AND OPTIONS (See Page 2)

	30F	40F	50F	60F	80F	100F
Standard Flue System	225540	225540	225540	225541	225541	225542
1 metre Flue System	N/A	N/A	N/A	N/A	N/A	225545
2 metre Flue System	225543	225543	225543	225544	225544	N/A
Vertical Flue System	225157	225158	225159	225160	225161	225162
90° Flue Bend Kit	225600	225600	225600	225600	N/A	N/A
45° Flue Bend Kit	225601	225601	225601	225601	N/A	N/A
Flue Elbow Kit (For use with Flue Bends)	225602	225603	225604	225605	N/A	N/A
Vertical Flue Terminal Kit (For use with Flue Bends)	225606	225607	225608	225609	N/A	N/A
1 metre Flue System	225545	225545	225545	225545	N/A	N/A
2 metre Flue System	225544	225544	225544	225544	N/A	N/A
Vertex Flue Kit	225700	225701	225702	225703	N/A	N/A
Vertex Flue 1 metre extension kit	B4265	B4265	B4265	B4265	N/A	N/A
Terminal Wall Plate	212306	212306	212306	212280	212280	212280
Terminal Guard	205792	205792	205792	205792	205792	205792
Internal Fitment Kit	225183	225183	225183	225184	225184	225184
Pump Cover Kit (6in)	225422	225422	225422	225422	225418	225418
Pump Cover Kit (7in - 12in)	225423	225423	225423	225423	225419	225419
Pump Cover Kit (13in - 18in)	225424	225424	225424	225424	225420	225420
Pump Cover Kit (19in - 24in)	225425	225425	225425	225425	225421	225421

STRAIGHT
FLUE
KITS

FLUE
BEND
KITS

VERTEX
FLUE
KITS

OTHER
KITS

INSTALLATION INSTRUCTIONS

It is the law that all gas appliances are installed and serviced by competent persons as stated in Gas Safety (Installation and Use) Regulations 1984.

For Health and Safety information see back page. Electrical testwork should be carried out by a competent person in accordance with the I.E.E. Wiring Regulations.

The boiler and its associated equipment will arrive on site in two cardboard cartons. The contents of each carton is as follows.

CARTON 1:- Boiler Pack

Boiler

Template

Literature Pack Containing:-

Installation and Servicing Instructions

User's Instructions

Control Systems Pipework and Wiring Guide

Auxiliary Pack Containing:-

Boiler Mounting Bracket

Gas Service Cock and Accessory Packs

CARTON 2:- Flue System Pack

Horizontal Flue Packs

Air/Flue Duct Assembly (length as ordered)

Flue Elbow Extension

Flue Terminal

Flue Sealing Collar

Rope Sealing Ring

Side Infill Panels-2 off

Vertical Flue Pack (2 cartons)

Air/Flue Duct Assembly

Flue Terminal

Terminal Cowl

Vertical Flue Adaptor

Accessory Pack

Side Infill Panels-2 off

Flue Installation Instructions

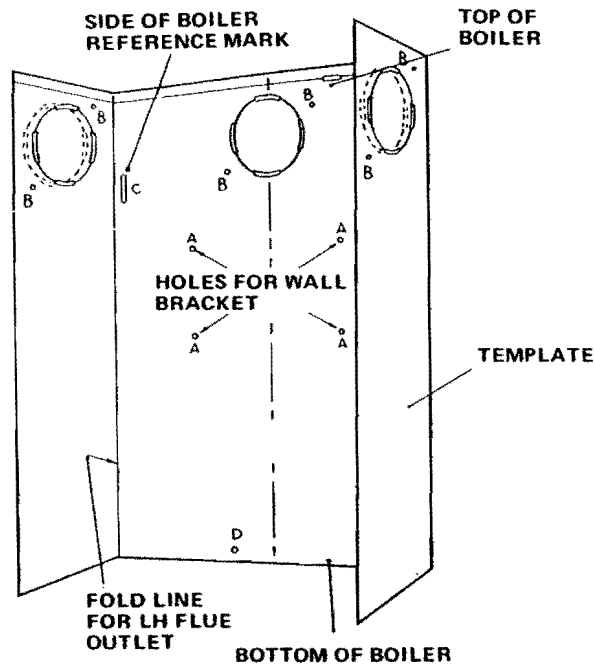

FIG. 8 TEMPLATE

Place template in proposed boiler position ensuring it is level (the minimum side clearances are automatically allowed for)

REAR FLUING

Mark holes 'A', 'B', 'D', large flue outlet hole and side of boiler reference lines through slots 'C'.

SIDE FLUING

Mark hole positions 'A', 'D' and side of boiler reference lines through slots 'C'.

Mark large flue outlet hole and holes 'B' using the thick lines on the template for minimum clearance at the rear of the boiler and the thin dotted lines for maximum clearance. See note on Fig. 1.

NOTE - Prima 30F, 40F and 50F only

If a flue bend kit is to be used, the correct flue hole size is obtained by placing the wall sealing collar centrally over the marked flue outlet position, and marking around the outside of the collar.

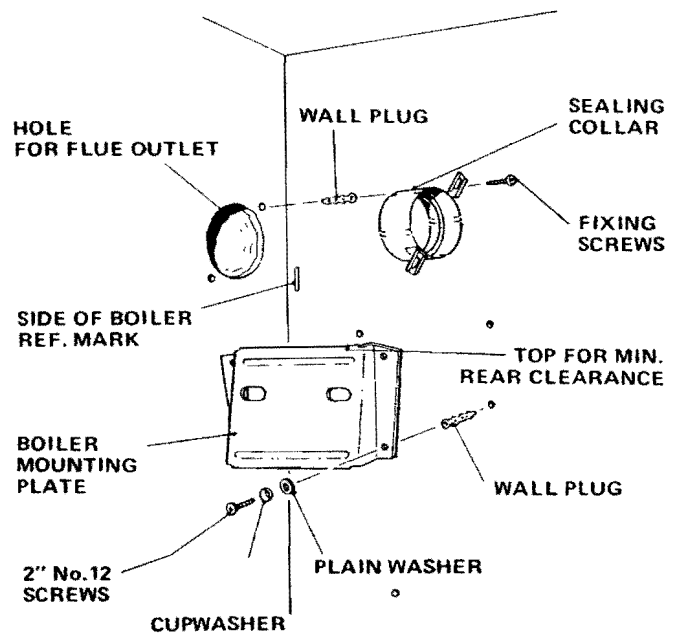

FIG. 9 BOILER MOUNTING PLATE

Remove template and carefully cut flue outlet hole through wall. If necessary make good around hole to enable holes 'B' to be drilled. (If internal flue fitment kit is being used refer to instructions supplied with kit).

Drill holes 'A' using a 7 mm drill

Drill holes 'B' and 'D' using a 5 mm drill

Using wall plugs, screws and washers (accessory pack A) attach boiler mounting plate to wall. Ensure that it is level and the correct way up, i.e. to provide the clearance at the rear of the boiler allowed for when marking out using the template. See also NOTE on FIG. 1.

Insert wall plugs into holes 'B' (accessory pack B) and hole 'D' (accessory pack D).

Insert flue sealing collar into wall and secure with screws provided, (accessory pack B). Make good the internal wall surface around flue sealing collar.

CUTTING AIR/FLUE DUCTS

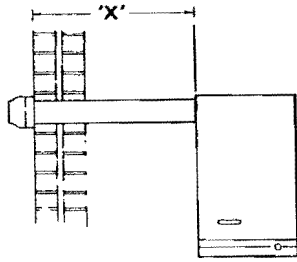

FIG. 10a SIDE FLUE

1. Measure from outside face of wall to the side of boiler casing reference line (dimension 'x').
2. Take air/flue duct assembly and measuring from the flanged end, mark and cut the outer duct and inner flue duct to dimension 'x' plus 20mm. Ensure that both ducts are cut squarely.

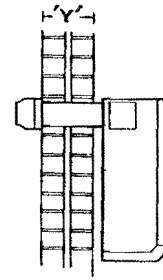

FIG. 10b REAR FLUE

1. Measure wall thickness (dimension 'Y').
2. Take air/flue duct assembly and measuring from the flanged end, mark and cut the outer air duct and inner flue duct to dimension 'Y', plus 45 mm. Ensure that both ducts are cut squarely.

NOTE

Cutting length remains the same for minimum or maximum clearance at the rear of the boiler.

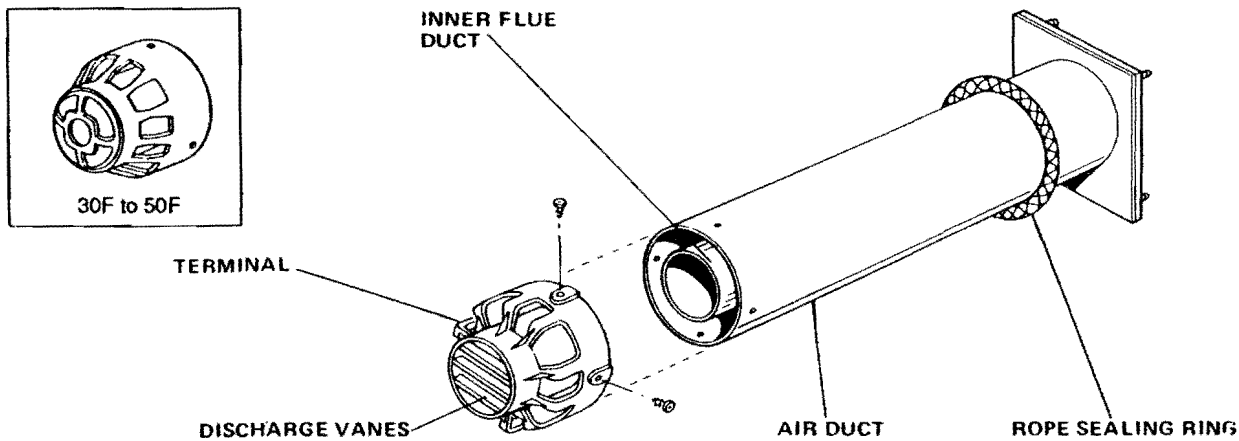

FIG. 11 AIR/FLUE DUCT ASSEMBLY

1. Slide rope sealing ring on to air duct.
2. Engage the terminal on to the ends of the inner flue duct and press fully home.

3. Engage four screws from accessory pack 'C' into the pre-drilled holes in the terminal and screw fully home.

These screws which are self drilling will pierce the air duct and secure the terminal to air duct.

On models 30F to 50F, it is necessary to drill four pilot holes in the air duct.

4. Protect duct where it is likely to come into contact with mortar by using adhesive tape provided (accessory pack E).

5. Insert the assembly into the wall sliding the rope sealing ring along the air duct into the flue sealing collar. Bend the six tabs on flue sealing collar inwards to retain the rope sealing ring. Ensure air duct flange studs do not obstruct lifting of boiler onto mounting bracket.

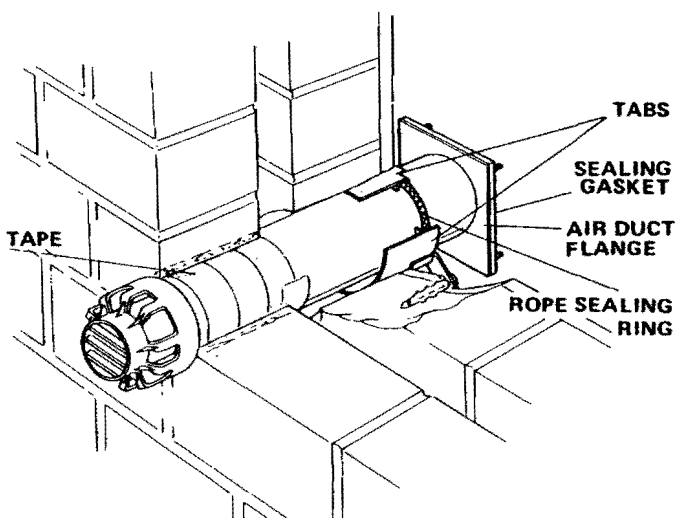

FIG. 12 SECTIONAL VIEW OF AIR/FLUE DUCT ASSY THROUGH WALL

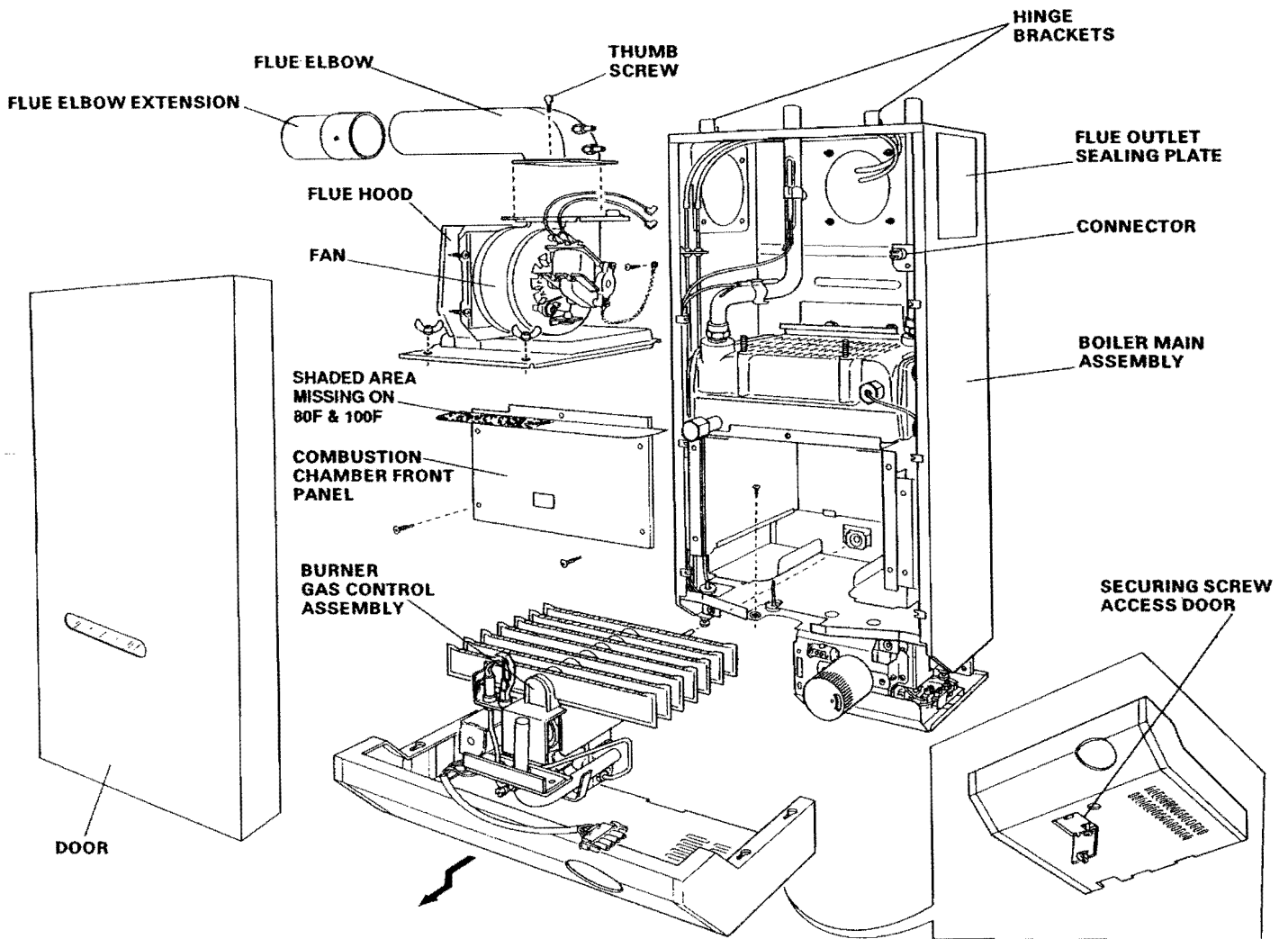

FIG. 13 PREPARING THE BOILER

The controls cover should have been removed when unpacking the boiler, if not remove controls cover by opening the door covering the securing screw on the underside of controls cover, see FIG 13.

Undo securing screw, pull controls cover forward 10 mm, lower to release from four side fixings and pull forward clear of thermostat knob.

Remove the door by undoing the lower fixing screws and lift door off the two upper hinge brackets.

Disconnect the two flexible tubes from the flue elbow.

Remove thumb screw securing the flue elbow and remove elbow by sliding forward to disengage it from its rear retaining flange.

NOTE

The boiler is supplied with the left hand flue outlet sealing plate removed. If another flue outlet direction is required, remove the appropriate flue outlet sealing plate and transfer it to the left hand position.

The boiler may now be lifted onto its mounting bracket or if desired the appliance lift weight can be further reduced by removing the fan/fluehood assembly also the burner/gas control assembly as follows.

1. Removing fan/fluehood assembly.

Disconnect the fan supply and earth leads from the connector adjacent to the fan. Remove the two wing nuts securing the flue hood to the heat exchanger. Lift out fan/fluehood assembly.

2. Removing burner/gas control assembly.

Remove the screws securing the combustion chamber front panel and remove panel. Unplug the electrical supply leads for the gas control valve from the control box.

Remove the screw securing the gas control valve to its support bracket.

Disconnect electrode lead from electrode.

Remove two screws securing the burner assembly to the bottom of the boiler case and lift out the burner/gas control assembly.

LIFTING THE BOILER

Lift the boiler onto its mounting bracket.

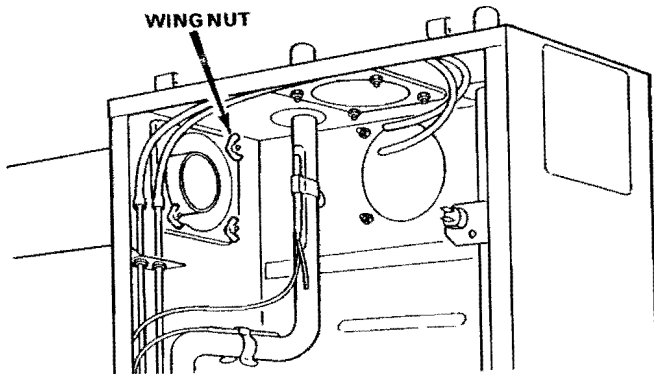

FIG. 14

Locate the studs on the air duct flange through the boiler casing and secure using four wing nuts (accessory pack F).

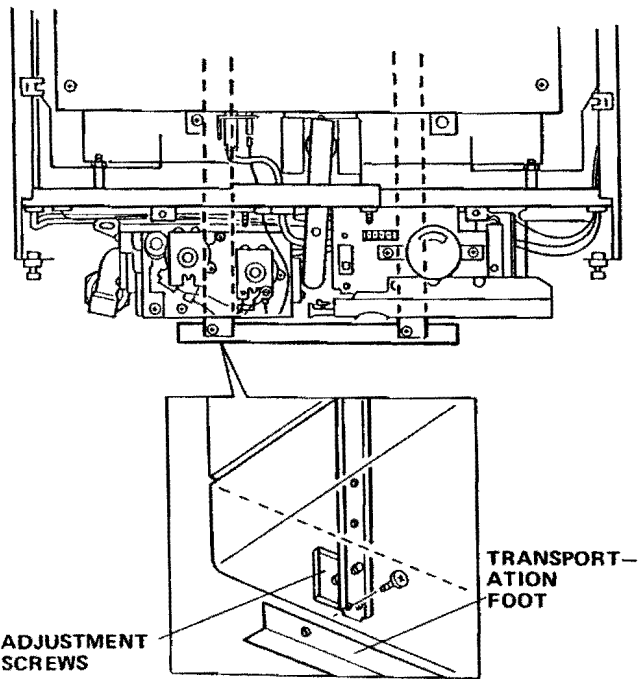

FIG. 15 TRANSPORTATION FOOT

Position boiler on its mounting bracket so that the sides of the boiler line up with the reference lines 'C' on the rear wall.

Undo the two screws securing the transportation foot and discard foot. Vertical alignment with rear wall can be corrected using the adjustment screws at the rear of the boiler. See FIGS. 15 & 16.

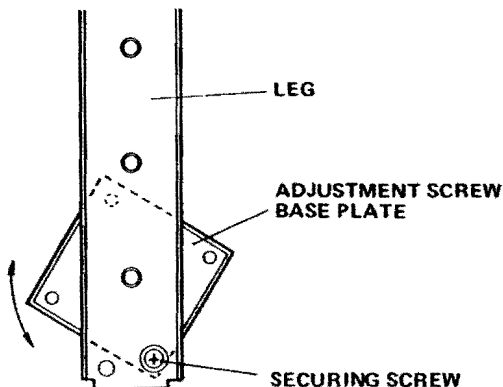

FIG. 16 SECURING BOILER

Rotate the left hand adjustment screw to align one of the holes in the base plate with hole 'D' in the wall. Working through the hole in the leg, secure the base plate to the wall using the screw from accessory pack D. Make good the wall surface around the flue terminal. Fit optional terminal wall plate if required.

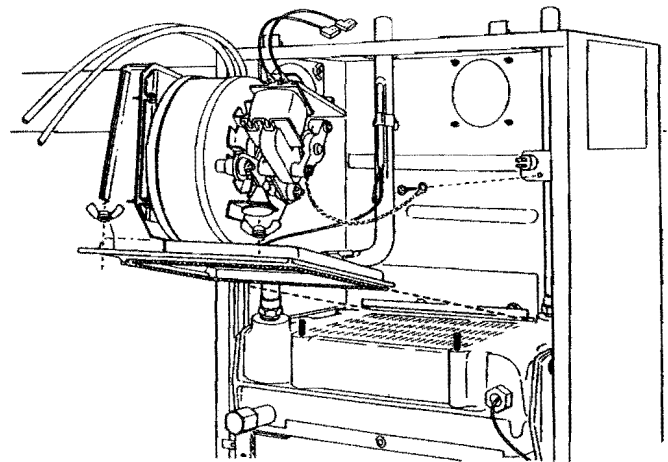

FIG. 17

If the fan/fluehood assembly or burner/gas control assembly were removed to reduce the appliance lift weight, refit them to the boiler. Reassembly is the reverse of removal. When refitting the burner/gas control assembly ensure that the locating pin on the rear of the burner engages correctly into the rear support bracket.

When refitting the fan/fluehood assembly ensure that the rear of the fluehood is correctly located beneath retaining flange. See FIG. 17.

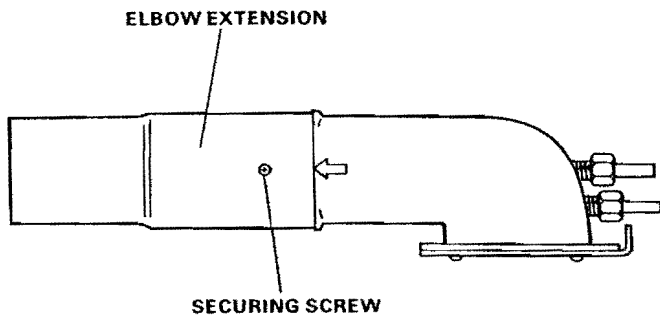

FIG. 18 FLUE ELBOW EXTENSION

When side fluing, slide the elbow extension onto the elbow, push on fully and align the hole for securing screw with arrow on elbow. Engage the screw from accessory pack 'C' into the pre-drilled hole in elbow extension and screw fully home. The screw which is self drilling will pierce the elbow and secure the extension to the elbow.

When rear fluing, the elbow extension should be discarded.

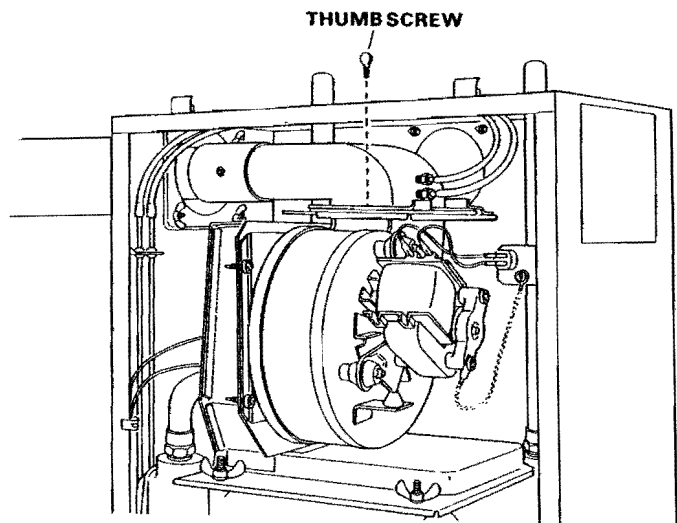

FIG. 19 LOCATION OF PRESSURE SENSING TUBES

Slide the flue elbow into the flue duct, ensure that the sealing gasket is in place and the elbow is correctly located beneath the retaining flange at the rear. See FIG. 19.

Secure elbow using thumb screw previously removed.

Reconnect flexible tubes to elbow.

ENSURE THEY ARE NOT KINKED.

The tubes are supplied at the length required for left hand flue outlet. When using rear or right hand flue outlets, to avoid kinking, the tubes should be shortened by 150mm. A band around the tube indicates the cutting point.

NOTE

Red tube connects the front aluminium tube to the lower connection on the elbow, each being identified with a red ring.

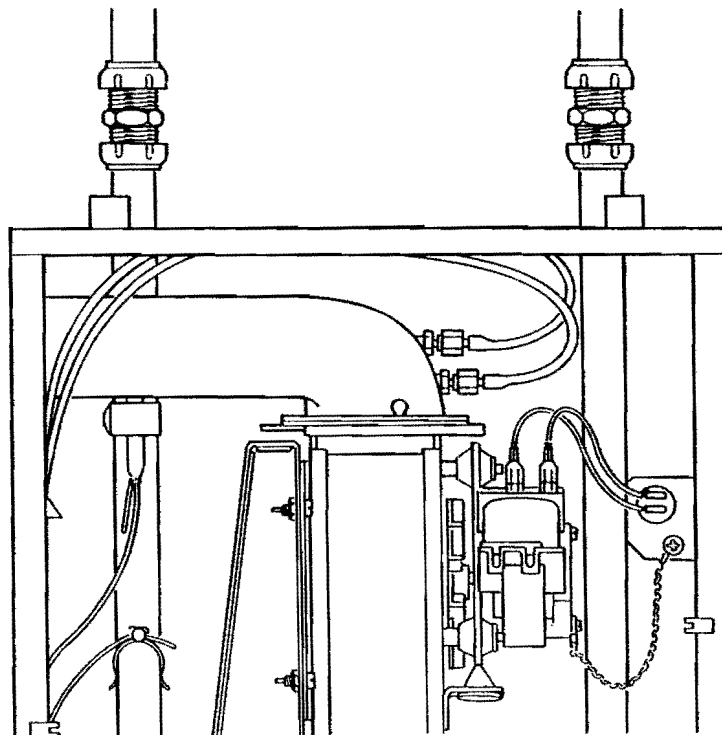

FIG. 20 PIPE CONNECTIONS

Connect system pipework to the boiler, compression fittings should be used. If however capillary fittings are used it is essential to temporarily remove both of the thermostat bulbs from the flow pipe before soldering.

A drain off tap should be installed close to the boiler if it is in a low point of the system. Connect the gas supply pipe to the inlet of the gas cock. Ensure the gas cock is in a position where it can be easily operated when the controls cover is removed.

ELECTRICAL

The boiler and all external control circuit wiring must be supplied from the same single isolating switch or plug and socket, and should be fused at 3A.

Care must be taken to ensure that all wiring to the boiler is kept clear of sharp edges and hot surfaces.

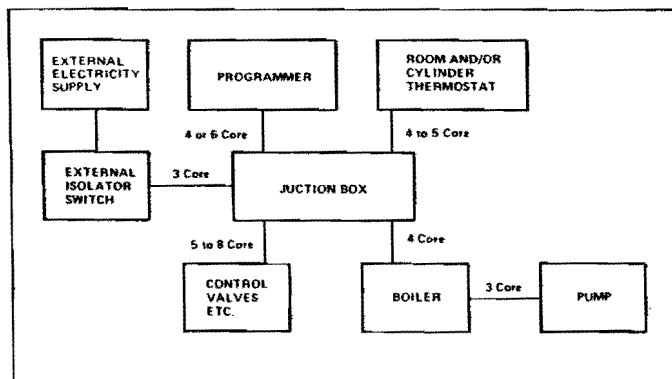

FIG. 21 PRINCIPLE OF WIRING

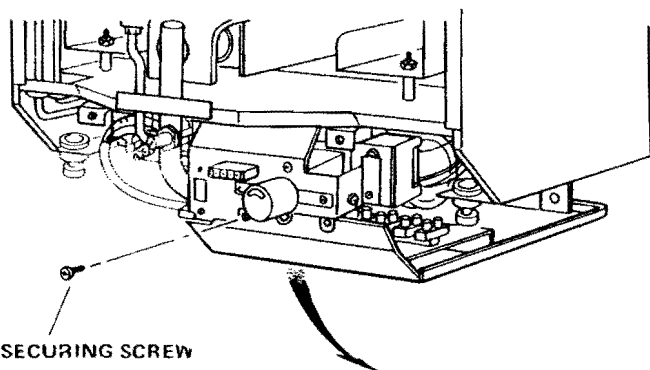

FIG. 22 ACCESS TO THE BOILER ELECTRICAL TERMINAL BLOCK

The boiler terminal block which is situated in the control box is not designed to accept wiring from all the on site controls and therefore the installer will usually need to incorporate a suitable junction box. This may not be required if a Potterton Electronic Programmer is used as this incorporates a junction box. The principle of wiring is shown in FIG. 21.

Further information on wiring of system controls can be found in the Control System, Pipework and Wiring Guide.

Remove control box securing screw and lower the control box to gain access to the boiler terminal block.

Remove packaging from rear of the control box.

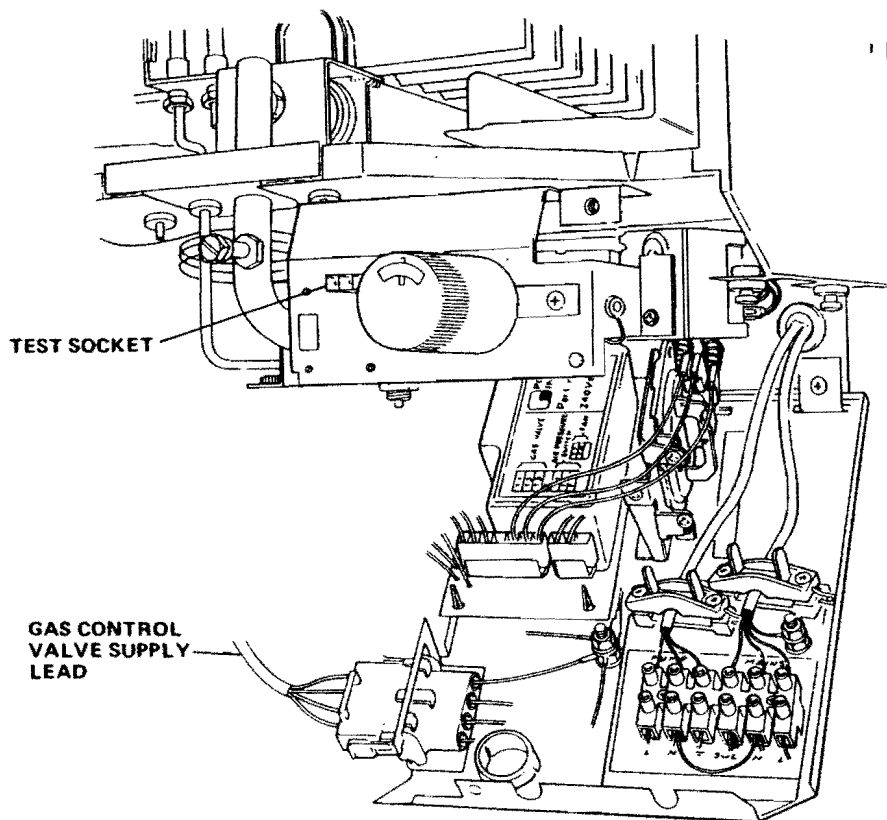

FIG. 23 ROUTING OF ELECTRICAL WIRING

Following the pump manufacturer's instructions connect the pump supply wires to terminals marked PUMP LN \perp on the boiler terminal block. Route the cable through the plastic bush in the rear of the control box as illustrated in FIG. 23 and secure, using the cable clamp.

Route a four core cable through the plastic bush in the rear of the control box and the cable clamp as illustrated in FIG. 23 and connect it to the boiler input terminals as follows:-

Permanent live to terminal marked MAINS 'L'.

Neutral to terminal marked MAINS 'N'.

Earth to terminal marked ' \perp ' adjacent to cable clamp. See NOTE.

Switched live from external controls to terminal marked MAINS 'SwL'.

If there are no external controls fitted connect the SwL terminal to permanent live in the junction box.

NOTE:

Ensure that the earth conductor is longer than the L, N & SwL from the point of anchorage, so that the current carrying conductors become taut before the earth conductor if cable is pulled out of the cable clamp. When the wiring has been completed close the control box and replace the securing screw.

FITTING SIDE INFILL PANELS

If required, the gap between the casing sides and rear wall can be closed off using the infill panels supplied.

Ensure the casing surface is FULLY CLEAN AND DRY. Remove the protective backing paper from the adhesive strip on the infill panel, carefully align and press into place, applying FIRM EVEN pressure down the FULL LENGTH of contact area between panel and case. If conditions are near freezing, the boiler case should be warmed prior to application of the infill panel.

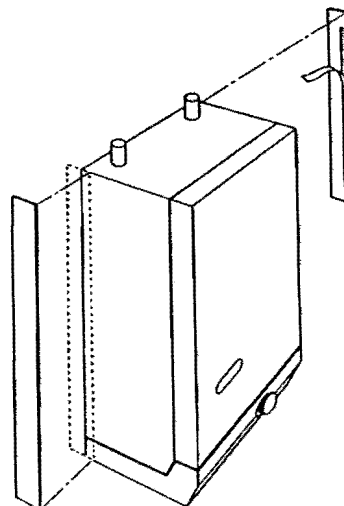

FIG. 24

COMMISSIONING

Open Vented Systems

Remove the pump and flush out the system thoroughly with cold water. Refit the pump. Fill and vent the system. Examine for leaks.

Sealed Systems

NOTE:

The system can be filled using a sealed system filler pump with a break tank or by any other method approved by the Local Water Authority. Refer to 'THE SYSTEM' section Page 8 in these instructions, also BS 6798 1987.

Remove pump and flush out the system thoroughly with cold water. Refit the pump. Fill and vent the system until the pressure gauge registers 1.5 bar (21.5 lbf/in²). Examine for leaks. Raise the pressure until the safety valve lifts. This should occur within ± 0.3 bar of the preset lift pressure of 3 bar. Release water to attain the correct cold fill pressure, and set the indicator on the water gauge to this value.

All Systems

The whole of the gas installation including the meter should be inspected and tested for soundness and purged in accordance with the recommendations of BS 6891.

Electrical testwork should be carried out by a competent person in accordance with the I.E.E. Wiring Regulations.

Test pilot unions for gas soundness as follows:—
Turn boiler thermostat to the 'O' position.

Unplug the gas control valve supply lead from the control box and plug it into the test socket adjacent to the boiler thermostat knob, See FIG. 23.

Turn on gas at the gas service cock.

Ensure that the time control if fitted is in an ON condition, and that the room and/or cylinder thermostats where fitted are set to high temperatures.

Switch on the external electricity supply to the boiler.

Gas will flow to the pilot only. It will not be ignited as the ignition system is de-energised.

Using a leak detection fluid, check pilot unions for gas soundness.

Turn off the external electricity supply and gas service cock.

Remove gas control valve plug from the test socket and refit the plug into the socket on the left hand side of the control box. See FIG. 23.

Refit the combustion chamber front panel.

Fit the case door into position by lifting it onto the top hinge brackets and secure it with the lower two fixing screws.

Remove the temporary label from the front of the appliance, having ensured compliance with the warnings on the label.

First Lighting

WARNING: Before lighting the boiler, ensure that the CASE DOOR HAS BEEN CORRECTLY FITTED and that the sealing strip fitted to the case door is forming a tight seal with the main boiler casing. Before proceeding to light the boiler, check that the external electricity supply to the boiler is switched off and that the boiler thermostat is in the 'O' position.

Turn on the gas service cock.

Ensure that the pump and radiator isolating valves are open.

Ensure that the time control, if fitted is in an on condition, and that the room and/or cylinder thermostats, where fitted are set to high temperatures.

Switch on the external electricity supply to the boiler.

After installation of the appliance, preliminary electrical system checks must be carried out. The checks to be carried out are:—

- A. Earth Continuity
- B. Short Circuit
- C. Polarity
- D. Resistance to Earth

Refer to Fault Finding Chart FIG. 30

Turn the boiler thermostat on and to a high setting and after a period of time the main burner will light, this can be observed through the sight glass in the front cover of the boiler. The time period can vary upwards of 45 seconds, depending on the amount of air in the pipework.

Test for gas soundness around the boiler components using leak detection fluid.

Turn the boiler thermostat to 'O'.

NOTE:

There could be a delay in lighting if the control knob is switched on and off and then on again rapidly.

SETTING AND CHECKING OF CONTROLS

With the controls cover removed.

Fit a pressure gauge to the pressure test nipple in burner supply pipe. See FIG. 2.

Turn on the boiler thermostat and ensure that the main burner is alight. Check that the burner pressure is in accordance with values stated under TECHNICAL DATA.

The burner pressure is set to the maximum output at the factory.

If burner pressure adjustment is necessary proceed as follows, referring to FIG. 25.

SIT GAS CONTROL VALVE

Remove the plastic cap from beneath the gas control valve and turn the pressure adjustment screw anti-clockwise to increase the pressure or clockwise to decrease the pressure.

HONEYWELL GAS CONTROL VALVE

Turn the pressure adjustment screw anti-clockwise to increase the pressure or clockwise to decrease the pressure.

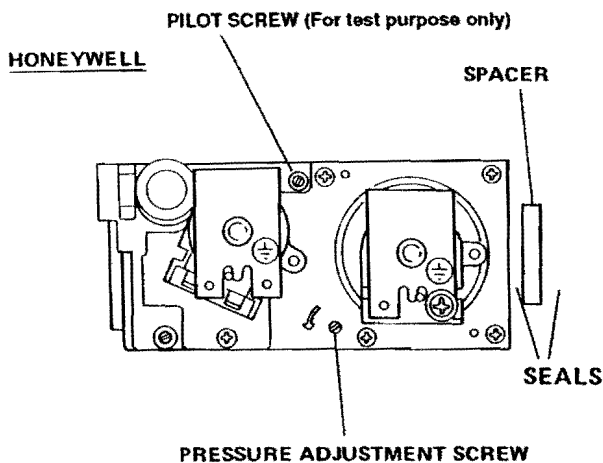

S.I.T.

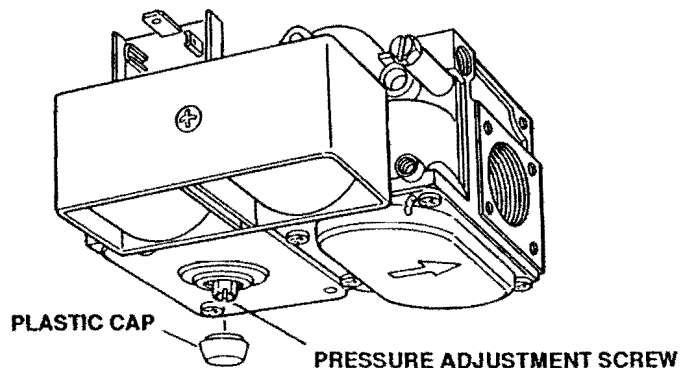

FIG. 25 MAIN BURNER PRESSURE ADJUSTMENT

With the burner set to its correct pressure, the firing rate given in TECHNICAL DATA should also be obtained and this should be checked by meter reading at least 10 minutes after the main burner has been lit. When the pressure and rate are correct replace the plastic cap on the SIT gas control valve.

Shut down the boiler remove the pressure gauge and refit the screw in the test nipple ensuring that a tight seal is made.

Remove the self-adhesive arrow from the inspection ticket tied to the burner supply pipe and stick it to the Data Plate inside the controls cover to indicate the appropriate burner setting pressure.

Refit the controls cover.

Relight the boiler and heat the system to maximum. Check for water leaks, turn the boiler off, drain the system whilst hot.

Refill the system and on sealed systems adjust to the correct cold fill pressure. Set the pressure gauge pointer to the system design pressure.

If a by-pass circuit is fitted the by-pass valve should be adjusted with the boiler operating under minimum load conditions to maintain sufficient water flow through the boiler to ensure that the overheat thermostat does not operate under normal operating conditions.

Pilot Burner

The pilot is pre-set and no adjustment is required. The pilot flame envelope should cover the electrode tip and spark earthing strip see FIG. 29. If the pilot flame is not as illustrated, remove and clean the pilot as described in the Servicing Instructions Section 4, PILOT BURNER, Page 22.

Boiler Thermostat

At its minimum and maximum settings, the thermostat should control the water flow temperature at approximately 55°C–82°C (130°F–180°F).

The thermostat has been calibrated by the makers and no attempt should be made to re-calibrate it on site. Turn the thermostat to the 'O' position and check that the main burner shuts down.

Pump Over-Run Thermostat

Will keep the pump running after the boiler has shut down, as long as the water temperature within the boiler is above 80°C.

The thermostat is preset and no adjustment is possible.

Overheat Thermostat

The overheat thermostat is pre-set and no adjustment is possible. It will require manually resetting if an overheat condition occurs. Access to the reset button is through a hole in the underside of the controls cover, see FIG. 2.

Other Boiler Controls

All boiler mounted controls are designed so that if any fault should occur they will fail safe. No further setting or checking is necessary.

External Controls

Check that any other external control connected in the system, such as clocks and thermostats, control the boiler as required.

User's Instructions

A User's Instructions leaflet is provided with this boiler but the householder must have the operation of the boiler and system explained by the Installer. The householder must also be advised of the importance of annual servicing and of the precautions necessary to prevent damage to the system and building, in the event of the system remaining out of commission in frost conditions.

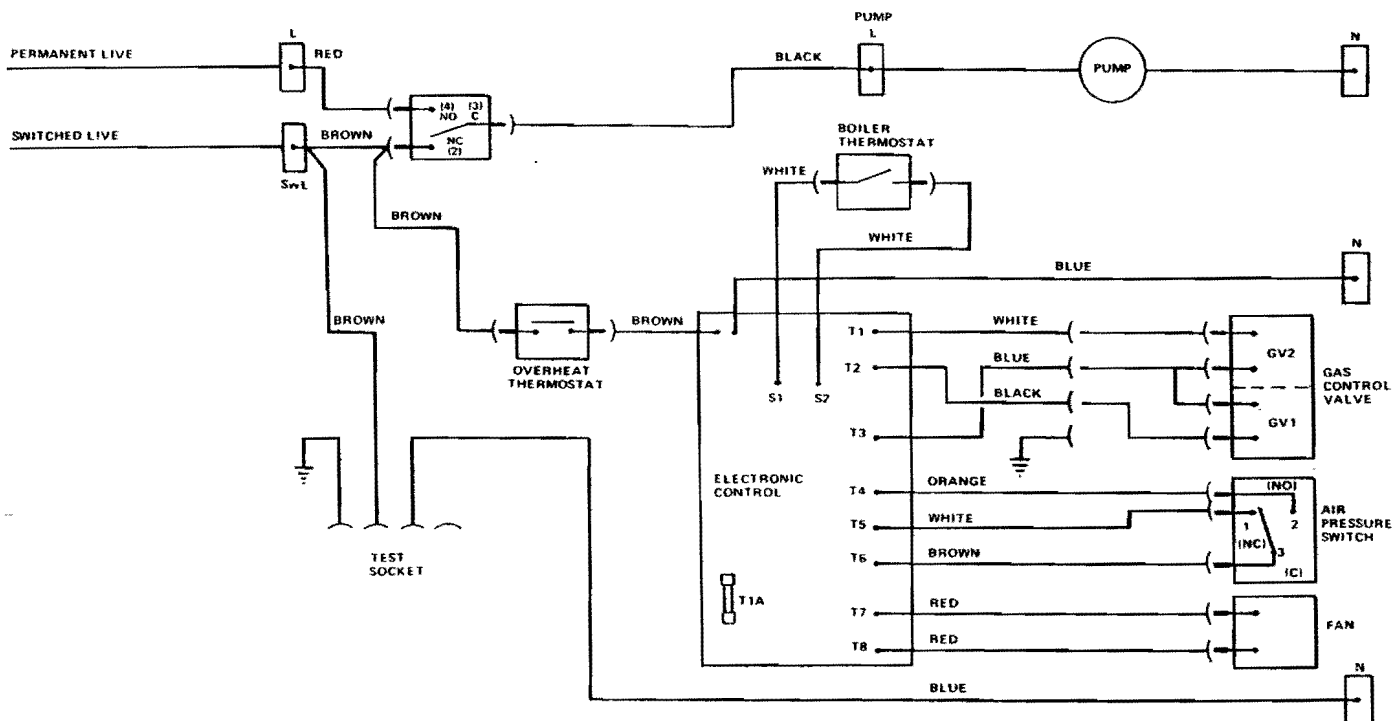

FIG. 26 FUNCTIONAL FLOW DIAGRAM

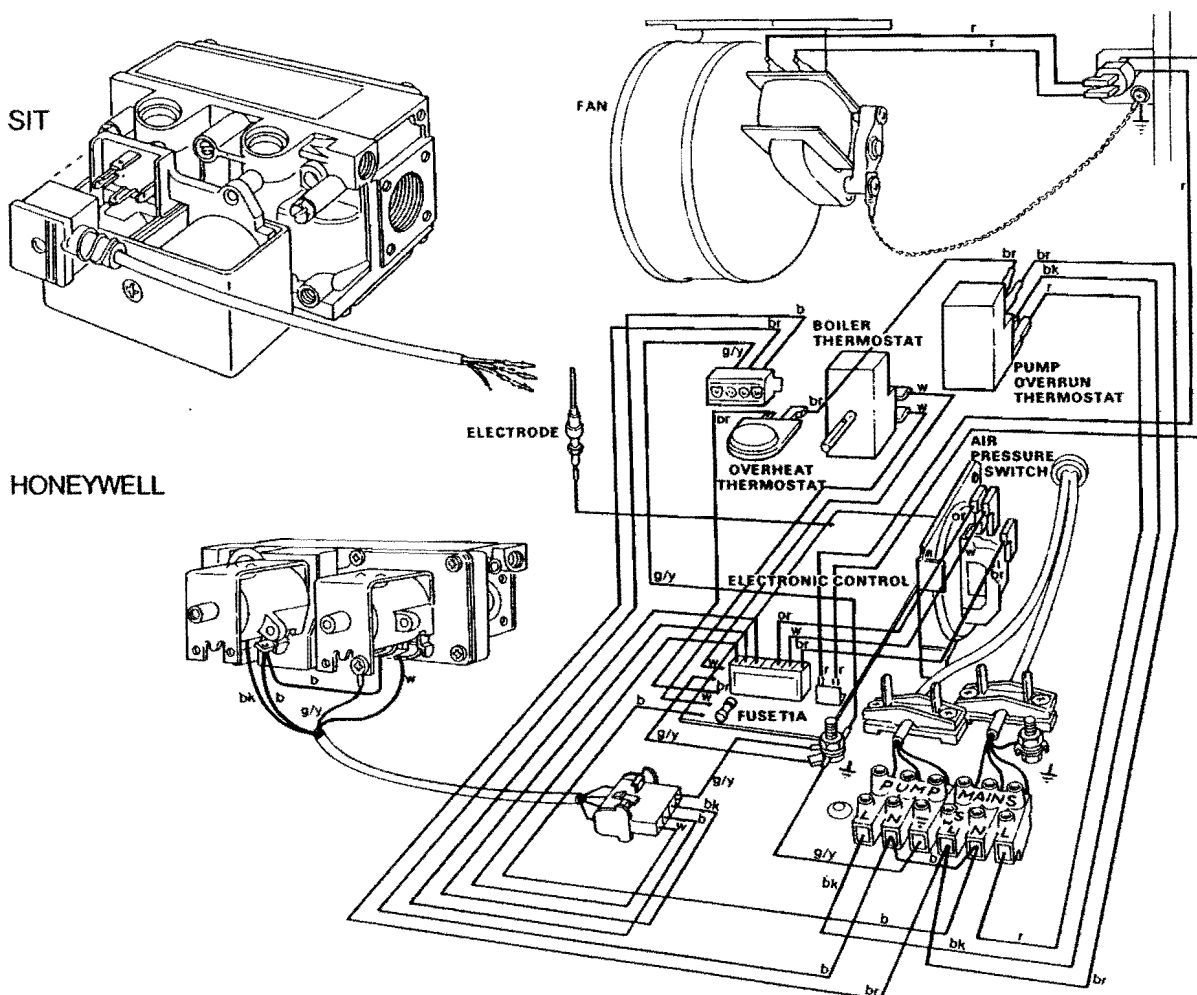

FIG. 27 BOILER WIRING DIAGRAM.

SERVICING INSTRUCTIONS

Regular skilled servicing and cleaning of the appliance is essential to ensure continued safe and efficient operation. The frequency of cleaning will depend upon the particular installation conditions, and the use to which the appliance is put, but in general, once per year should be adequate.

It is the law that all gas appliances are installed and serviced by competent persons as stated in Gas Safety (Installation and Use) Regulations 1984. For Health and Safety Information see back page.

Electrical installation and servicing should be carried out by a competent person in accordance with the I.E.E. Wiring Regulations.

Servicing is best arranged by a contract placed with Potterton Myson Limited and further details are available from the local Potterton Regional Service Office.

The boiler DATA PLATE and WIRING DIAGRAM are attached to the inside of the controls cover. The boiler CODE NUMBER which should be quoted when ordering spares or requesting information is on the front of the control box. See FIG. 2.

All parts likely to require servicing are readily accessible. By removing the cover from the boiler controls and removing the front door from the boiler, most components are exposed. Remove the front of the combustion chamber to gain access to the main and pilot burner and the ignition electrode.

Removal of the flue elbow, fan and fluehood will expose the flueways in the heat exchanger for cleaning.

The following notes apply to the boiler and its controls but it should be remembered that attention must also be

paid to the heating circuit itself including radiator valves, thermostats, the time control and the expansion and feed water system. It is advisable to clean the boiler immediately after the end of the heating season.

In all cases prior to servicing, light up the boiler and check that the pilot and main burners have a clean, even flame and that the gas rate and main burner pressure are correctly set. If the pilot flame is satisfactory, no further servicing of the pilot burner is necessary and the information given in '4. PILOT BURNER' can be ignored.

WARNING

Before the start of any servicing work, switch off at the external electricity supply by disconnecting the supply plug at the socket or switching off the external isolating switch. Turn off the gas service cock.

NOTE: After completing any servicing or replacement of components check for gas soundness and carry out functional checks.

1. PREPARING THE BOILER FOR SERVICING

See FIG. 13.

NOTE: Boilers with side or rear flues have a flue elbow fitted to the fluehood.

The elbow is replaced by an adapter on vertically flued boilers.

- A. Remove controls cover by opening the door covering the securing screw on the underside of the controls cover, see FIG. 13. Undo securing screw, pull controls cover forward 10mm, lower it to release it from its four side fixings and pull forward clear of the thermostat knob.
- B. Remove door by undoing the lower fixing screws and lift door off the two upper hinge brackets.

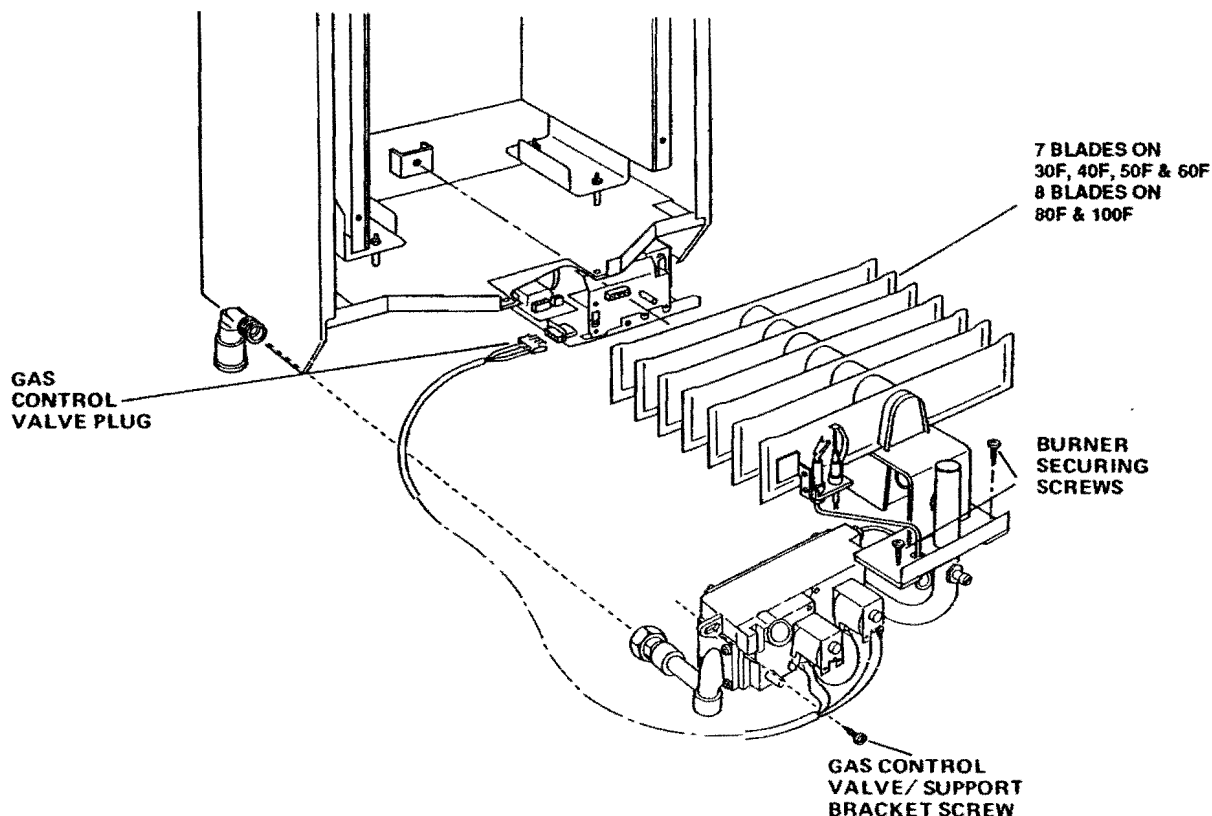

FIG. 28 BURNER AND GAS CONTROL ASSEMBLY

- C. Remove screws securing the combustion chamber front panel and remove panel.
- D. Disconnect the two flexible tubes from the flue elbow.
- E. Remove thumb screw securing the flue elbow and withdraw elbow. Take care not to damage the gasket. On vertically flued boilers remove two thumb screws and slide the vertical flue adapter up into the flue duct.
- F. Disconnect the fan supply and earth leads from the connector adjacent to the fan. Remove the two wing nuts securing the flue hood to the heat exchanger. Lift out fan/flue hood assembly.
Lower and lift out vertical adapter.
- G. Undo the union on the gas service cock outlet.
- H. Unplug the electrical supply leads for the gas control valve from control box. See FIG. 28.
 - I. Remove the screw securing the gas control valve to its support bracket. See FIG. 28.
- J. Disconnect the electrode lead from electrode.
- K. Remove two screws securing the burner assembly to the bottom of the boiler case and lift out the burner and gas control assembly.

2. HEAT EXCHANGER

- A. Working from above and below the heat exchanger use a suitable tool and remove all deposits from between the fins.

Slide vertical flue adapter into flue duct.

3. FAN

- A. Separate fan from fluehood by removing the two securing screws.

Carefully clean any deposits from around the fan motor and its supports. Examine the fan wheel and clean if necessary using a soft brush.

Re-assemble fan to fluehood ensuring that the sealing gasket is in place and in good condition. Ensure also that the fan is located correctly in the rear retaining bracket.

Secure with two screws.

- B. Refit the fan/fluehood assembly. Ensure that the rope seal is in place and the rear of the fluehood is correctly located beneath the retaining flange. See FIG. 17. Secure with two wing nuts.
- C. Slide flue elbow into the flue duct or lower flue adapter and secure with thumb screws. Ensure that the gasket between fan outlet and elbow or adapter is undamaged and in place.
- D. Reconnect the flexible tubes to elbow or adapter. ENSURE THEY ARE NOT KINKED.

NOTE

Red tube connects front aluminium tube to the lower connection on elbow or adapter each being identified with a red ring.

- E. Reconnect the fan supply and earth leads.

4. PILOT BURNER

The following operations are only necessary if the pilot flame is distorted or the wrong size, ie too small.

- A. Unscrew the pilot tube from the pilot assembly. Take care not to damage the electrode.

- B. Unscrew the two hexagonal head screws securing the pilot to the main burner and remove pilot assembly and shield where fitted, be careful that the pilot injector does not fall out during this operation.
- C. Lightly brush the pilot to remove any deposits. Remove the pilot injector and clean its orifice or replace.

NOTE

Do not use a wire brush or pin to clean injector.

- D. Gently clean any deposits from the electrode.
- E. Refit the pilot injector to the pilot burner and assemble the pilot to the pilot tube.
- F. Secure the pilot assembly to the main burner using two hexagonal screws.
- G. Fully tighten the union nut connecting the pilot tube to the pilot. Check for gas soundness at this joint by following the procedure described in the commissioning section of these instructions. Page 18.
- H. Ensure that the spark gap is as illustrated in FIG. 29.

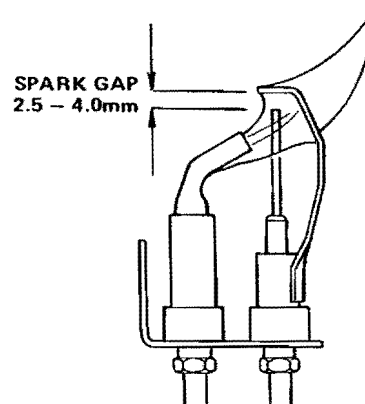

FIG. 29 PILOT BURNER SPARK GAP TOLERANCES

PILOT FILTER

The pilot burner is protected from blockage by a pilot filter situated within the gas control valve. The filter is large and designed to last the life of the gas control valve under normal operating conditions, it is therefore unlikely to need replacing. However in the event of pilot filter blockage being suspected the complete control valve should be replaced.

5. COMBUSTION CHAMBER INSULATION

- A. Check the combustion chamber insulation for damage. If damaged replace as described under replacement.

6. MAIN BURNER

- A. Lightly brush any deposits from the top of each blade and ensure there is no fluff in the entry of the burner venturi. If on re-assembly the burner flame picture is incorrect or the correct gas rate or burner pressure cannot be obtained, remove the burner and gas control assembly and thoroughly clean the burner. Clean or replace the injector. In the event of the above procedures not rectifying the flame appearance, disconnect the burner from the gas control valve at the flanged connection and replace the burner and injector.

- B. Refit the burner and gas control valve assembly into the boiler, ensuring that the locating pin on the rear of burner engages correctly into the rear support bracket. Make sure that the sealing gasket is in place and undamaged between the burner flange and the case. Secure the assembly with two screws.
- C. Refit the screw securing the gas control valve to the support bracket.
- D. Reconnect electrode lead to electrode.
- E. Plug gas control valve supply leads into control box.
- F. Reconnect gas supply at gas service cock and turn on gas.
- G. Refit the combustion chamber front panel.

7. CASE SEAL

Check the case door seal. Replace if damaged. The seal is simply pressed into the channel around the door.

8. RECOMMISSION

Follow the full commissioning procedure as detailed in the COMMISSIONING section of these instructions page 18.

9. OTHER BOILER MOUNTED UNITS

No further servicing is required on any other boiler mounted units. Repair is by replacement.

10. FAULT FINDING

Refer to Fault Finding Chart FIG. 30 and Wiring Diagram FIGS. 26, 27.

REMOVAL/REPLACEMENT OF BOILER MOUNTED UNITS

GAS CONTROL VALVE

This operation is most easily carried out by first removing the burner and gas control valve assembly as follows:-

1. Switch off the external electricity supply by disconnecting the plug at the socket or switching off the external isolating switch.
2. Remove controls cover, case door and combustion chamber front panel as described in 1. 'Preparing the Boiler for Servicing', operations A, B and C.
3. Remove the burner and gas control assembly as described in 1. 'Preparing the Boiler for Servicing', operations G, H, I, J & K.
4. Disconnect the electrical supply from the gas valve. With Honeywell, note the individual wire positions. Refer to FIGS. 26 and 27.
5. Unscrew the union connecting the pilot supply pipe to the gas control valve.
6. Separate the gas control valve from the flanges at the inlet and outlet ports by removing the securing screws.

NOTE: With the Honeywell gas control valve a spacer is used between the valve outlet and the burner flange, requiring the use of two seals at this point. See FIG. 25.

7. Use new seals on reassembly.
8. Replacement is the reverse of removal.
9. Follow the full commissioning procedure as detailed in the COMMISSIONING section of these instructions. Page 18.

MAIN BURNER

1. Switch off the external electricity supply by disconnecting the plug at the socket or switching off the external isolating switch.
2. Remove controls cover, case door and combustion chamber front panel as described in 1. 'Preparing the Boiler for Servicing', operations A, B and C.
3. Remove the burner and gas control assembly as described in 1. 'Preparing the Boiler for Servicing', operations G, H, I, J & K.
4. Unscrew the union nuts connecting the pilot supply pipe to the pilot and gas control valve. Take care not to damage the electrode and be careful that the pilot injector does not fall out during this operation.

Remove sealing grommet and withdraw the pilot tube through the hole in the burner mounting flange.

5. Separate the burner from the gas control valve at the flanged connection by removing the four securing screws.

NOTE: With the Honeywell gas control valve a spacer is used between the valve outlet and the burner flange, requiring the use of two seals at this point. See FIG. 25.

6. Unscrew the pilot, main burner injector and pressure test nipple from the burner.
7. Use new sealing gaskets on reassembly.
8. Replacement is the reverse of removal.
9. Follow the full commissioning procedure as detailed in the COMMISSIONING section of these instructions. Page 18.

PILOT/IGNITION ELECTRODE

1. Switch off the external electricity supply by disconnecting the plug at the socket or switching off the external isolating switch.
2. Remove controls cover, case door and combustion chamber front panel as described in 1. 'Preparing the Boiler for Servicing', operations A, B and C.
3. Disconnect the electrode lead from electrode.
4. Unscrew the aluminium pilot tube from the pilot assembly. Take care not to damage the electrode.
5. Unscrew the two hexagonal head screws securing the pilot to the main burner and remove the pilot assembly and shield where fitted, be careful that the pilot injector does not fall out during this operation.
Unscrew electrode retaining nut and withdraw the electrode.
6. Replacement is the reverse of removal. On re-assembly ensure that the spark gap is as illustrated in FIG. 29.
7. Follow the full commissioning procedure as detailed in the COMMISSIONING section of these instructions. Page 18.

COMBUSTION CHAMBER INSULATION

1. Switch off the external electricity supply by disconnecting the plug at the socket or switching off the external isolating switch.
2. Remove controls cover, case door and combustion chamber front panel as described in 1. 'Preparing

the Boiler for Servicing', operations A, B and C.

3. Remove main burner as described in 'Preparing the Boiler for Servicing', operations G, H, I, J & K.
4. Bend back retaining tabs and replace insulation. It is necessary to first remove the side insulation when replacing the rear.
5. Replacement is the reverse of removal.
6. Follow the full commissioning procedure as detailed in the COMMISSIONING section of these instructions. Page 18.

FUSE, ELECTRONIC CONTROL, PRESSURE SWITCH, BOILER THERMOSTAT, OVERHEAT THERMOSTAT, PUMP OVERRUN THERMOSTAT

The following initial operations 1-3 are necessary to remove and replace any of the above items.

1. Switch off the external electricity supply by disconnecting the plug at the socket or switching off the external isolating switch.
2. Remove controls cover by opening the door covering the securing screw on the underside of the controls cover see FIG. 13. Undo securing screw, pull controls cover forward 10mm, lower it to release it from its four side fixings and pull forward clear of the thermostat knob.
3. Remove control box securing screw and lower control box.

FUSE 1 amp

4. The fuse is located on the electronic control and can be replaced by lifting it from its holder.
5. Replacement is the reverse of removal. Refer to FIGS. 26 & 27.

ELECTRONIC CONTROL

4. Disconnect six way plug, two way plug and electrode lead from the electronic control. Refer to FIGS. 26 & 27.

Disconnect the flying leads of the electronic control as follows:-

white wire from terminal C(3) of the control thermostat

white wire from terminal NC (2) of the control thermostat

brown wire from overheat thermostat

blue wire from boiler terminal block connector N

green/yellow wire from earth post

5. Release the control by lifting it from the four retaining lugs.
6. Remove electronic control.
7. Replacement is the reverse of removal.
8. Follow the full commissioning procedure as detailed in the COMMISSIONING section of these instructions. Page 18.

PRESSURE SWITCH

4. Remove the screw securing the pressure switch to the bracket in the control box. Lift pressure switch from bracket.
5. Disconnect the two plastic tubes. NOTE: the red tube is connected to the pressure switch connec-

tion identified with a red ring, or adjacent red spot.

6. Disconnect the three electrical leads, white wire from terminal No. 1 or NC, orange from terminal No. 2 or NO and brown from terminal No. 3 or C. Refer to FIGS 26 & 27.
7. Replacement is the reverse of removal. Ensure that the plastic tubes have the coiled springs positioned to prevent the tubes from kinking.
8. Follow the full commissioning procedure as detailed in the COMMISSIONING section of these instructions. Page 18.

OVERHEAT THERMOSTAT

4. Remove door by undoing the two lower fixing screws and lifting door off the two upper hinge brackets.
5. Disconnect the two push on electrical connections from the overheat thermostat terminals.
6. Remove the nut securing the overheat thermostat to its mounting bracket.
7. Noting the route taken by the capillary, remove split pin retaining the thermostat bulb and withdraw bulb from its pocket. Remove the split grommet in the base of the boiler, feed the thermostat capillary and bulb through the hole.
8. Replacement is the reverse of removal. Ensure the rubber grommet in the base of the boiler makes a good seal around the capillary. Ensure that the capillary is secure in the clips provided. Refer to FIG. 2. The bulb of the new thermostat should be coated with heat conducting paste.
9. Follow the full commissioning procedure as detailed in the COMMISSIONING section of these instructions. Page 18.

BOILER THERMOSTAT

4. Remove door by undoing the two lower fixing screws and lifting door off the two upper hinge brackets.
5. Disconnect the electrical connections as follows:-
White from terminal C(3). White from NC(2)
Refer to FIGS. 26 & 27.
6. Pull off the outer thermostat knob.
7. Remove inner thermostat post by undoing the two securing screws.
8. Remove the nut securing the thermostat to the control box.
9. Remove the clip securing the thermostat bulb to the flow pipe.
10. Remove the split grommet in the base of the boiler. Feed the capillary and bulb through the holes.

Replacement is the reverse of removal. The bulb of the new thermostat should be coated with heat conducting paste. Ensure the rubber grommets in the base of the boiler make a good seal around the capillary.

Ensure that the capillary is secure in the clips provided.

Follow the full commissioning procedure as detailed in the COMMISSIONING section of these instructions. Page 18.

PUMP OVER-RUN THERMOSTAT

4. Remove door by undoing the lower fixing screws and lifting door off the two upper hinge brackets.
5. Disconnect the electrical connections as follows:-
 - 1 red wire from terminal NO(4)
 - 2 brown wires from terminal NC(2)
 - 1 black wire from terminal C(3)
6. Remove the screw securing the thermostat to the control box.
7. Remove the clip securing the thermostat bulb to the flow pipe.
8. Remove the split grommet in the base of the boiler. Feed the capillary and bulb through the hole.
9. Replacement is the reverse of removal. The bulb of the new thermostat should be coated with heat conducting paste. Ensure the rubber grommet makes a good seal around the capillary.
10. Ensure that the capillary is secure in the clips provided. Follow the full commissioning procedure as detailed in the COMMISSIONING section of these instructions. Page 18.

SIGHT GLASS

WARNING: GREAT CARE SHOULD BE TAKEN WHEN HANDLING AND DISPOSING OF A BROKEN SIGHT GLASS.

3. Remove door by undoing the lower fixing screws and lift door off the two upper hinge brackets.
4. Remove three M4 nuts from sight glass retainer and

remove sight glass assembly. **See above.**

5. Replacement is the reverse of removal. Taking care that the clear circle in the sight glass lines up viewing hole in combustion chamber door. NOTE new gaskets must be used when sight glass is fitted.

FAN

1. Switch off the external electricity supply by disconnecting the plug at the socket or switching off the external isolating switch.
2. Remove controls cover and case door as described in 1. 'Preparing the Boiler for Servicing', operations A and B.
3. Disconnect the two flexible tubes from the flue elbow.
4. Remove thumb screw securing the flue elbow and withdraw elbow. Take care not to damage the gasket. On vertically flued boilers remove two thumb screws and slide the vertical flue adapter up into the flue duct.
5. Disconnect the fan supply and earth leads from the connector adjacent to the fan.
6. Separate fan from fluehood by removing the two securing screws.
7. Replacement is the reverse of removal. Ensure on reassembly that the fan is correctly located in the rear retaining bracket.
8. Follow the full commissioning procedure as detailed in the COMMISSIONING section of these instructions. Page 18.

TEST PROCEDURE FOR MEASURING FLAME CURRENT

Honeywell Valve

Disconnect the white wire from GV2 on gas control valve and connect it via a suitable test switch to neutral as shown. Set test switch to OFF. Insert an approved ammeter in series with the spark electrode. Turn ON the electricity supply and restart the boiler. NOTE: The pilot will light but not the main burner as GV2 is disconnected. When the pilot is established set the test switch to ON. This will stop the spark and allow a steady flame current to be measured.

TEST PROCEDURE FOR MEASURING FLAME CURRENT

S.I.T. Valve

Switch off external electricity supply to boiler. Remove boiler door. Unplug the gas control supply lead from the control box and plug it into the test socket. (See FIG. 23). Insert an approved ammeter in series with the spark electrode. Turn boiler thermostat to OFF. Re-instate the external electricity supply. Gas will flow to the pilot only, which can now be lit manually, enabling a steady flame current to be measured.

FLAME SUPERVISION TESTING

With the boiler running, turn off at the boiler thermostat. Temporarily restrict the pilot gas supply by fully screwing in the gas valve pilot screw clockwise. Turn on at the boiler thermostat; a spark will be present, indicating GV2 is electrically disconnected, and the boiler will not light. Now re-instate the pilot supply (three complete anti-clockwise turns); pilot and main boiler will light in the normal manner.

26

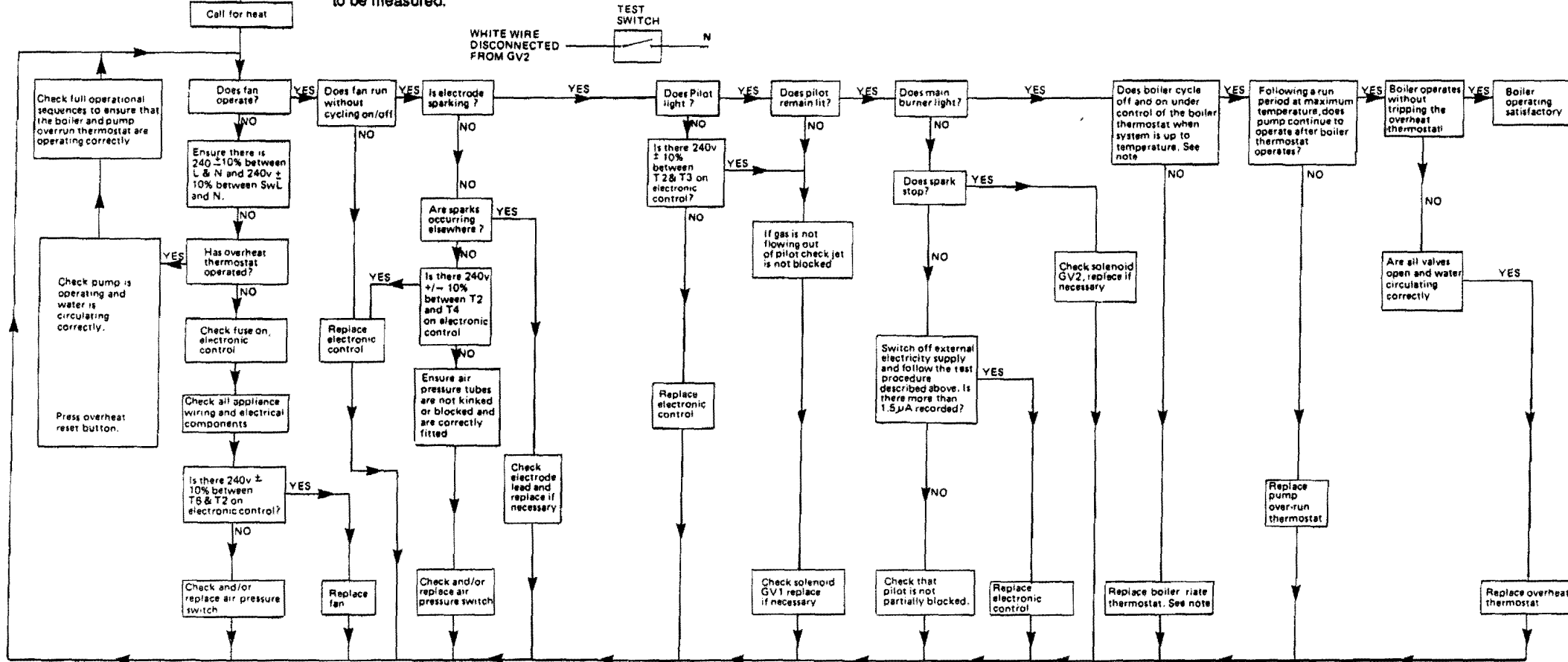

FIG. 30 FAULT FINDING CHART

SHORT PARTS LIST
KEY No.

P.I.L.
Part No.

G.C.
Part No.

1	Pilot and Electrode Assembly including items 2-4	907739	337 969
2	Pilot Injector	402915	381 656
3	Shear Off Union 30F-80F Boiler	402350	357 714
	Olive 100F Boiler	402944	337 859
	Nut 100F Boiler	402955	337 858
4	Electrode	402925	382 448
5	Electrode Lead	407698	337 863
6	Control Thermostat K36 L1014	404504	358 853
7	Gas Control Valve Kit - Honeywell VR4700E1034	907704	395 796
8	Gas Control Valve Kit - SIT Tandem 0830010	909029	289 396
9	Gas Manifold Gasket	212105	337 480
10	Gas Manifold 'O' Ring	401637	337 467
11	Pump Over-Run Thermostat K36 P2302	404507	378 024
12	Flue Elbow Sealing Gasket	225091	338 316
13	Electronic Control	407677	382 462
14	Fuse (1 amp) T1A	907604	337 338
15	Thermostat Knob	225251	338 445
16	Pressure Switch - Honeywell C6065A1192	642220	378 036
17	Fan Assembly - SEL (c.w. Gasket) 30F-60F Boiler	909000	338 318
	Fan Assembly - SEL (c.w. Gasket) 80F & 100F Boiler	909001	338 319
18	Overheat Thermostat LM7 P8503	404495	382 455
19	Main Burner Gasket	212085	337 371
20	2.9mm Injector - Main Burner 30F Boiler	410965	337 374
	3.1mm Injector - Main Burner 40F Boiler	410966	337 375
	3.5mm Injector - Main Burner 50F Boiler	410967	337 376
	3.6mm Injector - Main Burner 60F Boiler	410984	338 343
	4.4mm Injector - Main Burner 80F Boiler	410969	338 378
	4.7mm Injector - Main Burner 100F Boiler	410985	388 344
21	Flue Scraper	907736	337 862

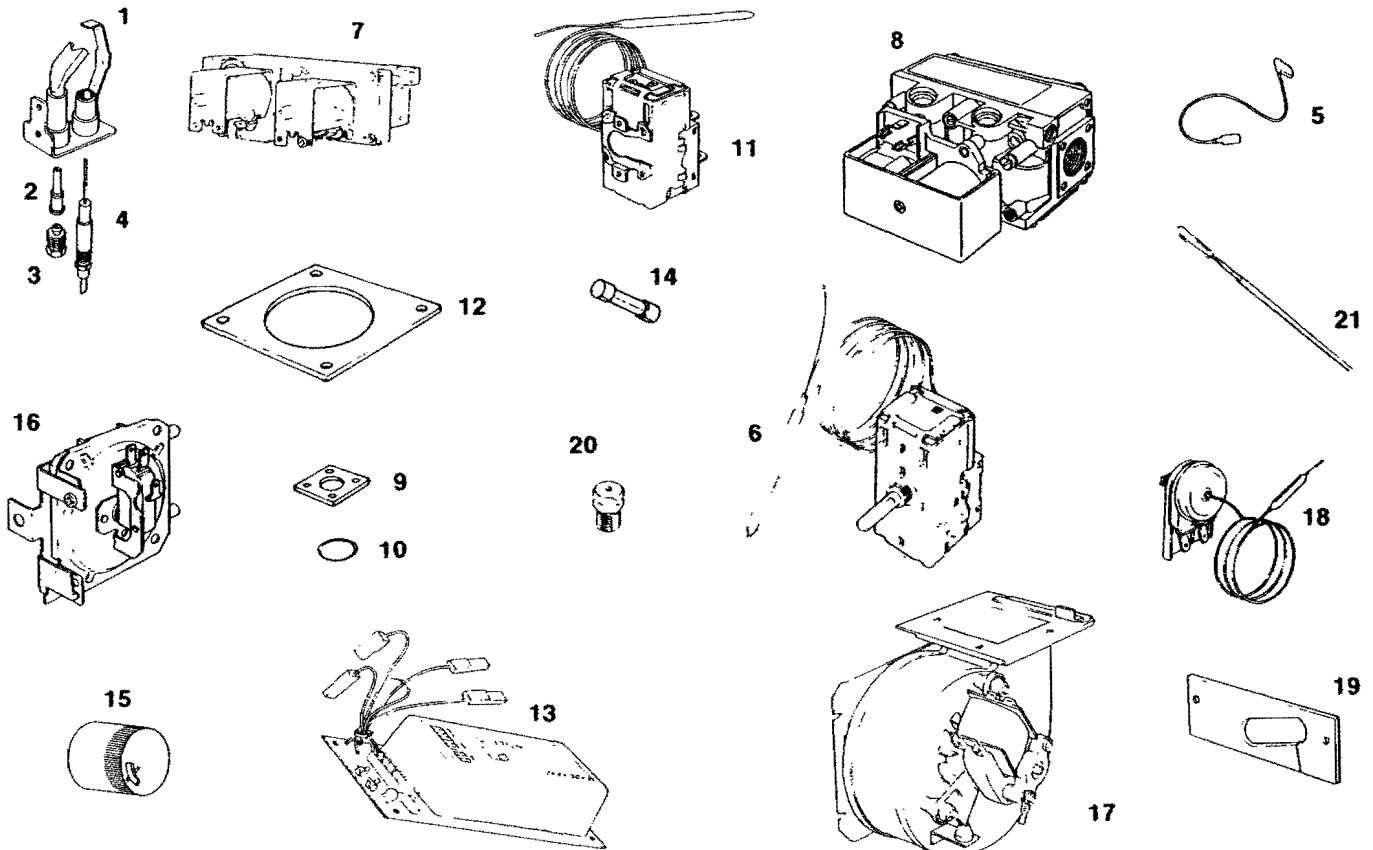

HEALTH AND SAFETY INFORMATION FOR THE INSTALLER AND SERVICE ENGINEER

Under the Consumer Protection Act 1987 and section 6 of the Health and Safety at Work Act 1974, we are required to provide information on substances hazardous to health.

Small quantities of adhesives and sealants used in the product are cured and present no known hazards.

The following substances are also present.

Insulation & Seals

Material	— Ceramic Fibre; Alumino — Silicone Fibre
Description	— Boards, Ropes, Gaskets
Known Hazards	— Some people can suffer reddening and itching of the skin. Fibre entry into the eye will cause foreign body irritation. Irritation to respiratory tract.
Precautions	— People with a history of skin complaints may be particularly susceptible to irritation. High dust levels are only likely to arise following harsh abrasion. In general, normal handling and use will not present discomfort, follow good hygiene practices, wash hands before consuming food, drinking or using the toilet.
First Aid	— Medical attention must be sought following eye contact or prolonged reddening of the skin.

Thermostat

Material	— Contains very small quantity of xylene.
Description	— Sealed phial and capillary containing liquid.
Known Hazards	— Irritating to skin, eyes and throat. Vapour is harmful. Inflammable — do not extinguish with water.
Precautions	— Do not incinerate. Avoid contact with broken/leaking phials. Do not purposely puncture.
First Aid	— Eye/skin contact, wash with clean water, seek medical attention.

Sales Enquiries: Sales Department Eastern Avenue Team Valley Trading Estate Gateshead Tyne & Wear NE11 0PG Tel: 0191 491 4466 Fax: 0191 491 7568	Service Enquiries: Service Department Brooks House Coventry Road Warwick CV34 4LL Tel: 01926 496896 Fax: 01926 410006	Spares Enquiries: Parts Division Queensway Leamington Spa Warwickshire CV31 3RG Tel: 01926 880600 Fax: 01926 880680	Technical Helpline: Technical Department Brooks House Coventry Road Warwick CV34 4LL Tel: 01926 410044 Fax: 01926 410006	Training Administration: Unit 5, Titan Business Centre Spartan Close Tachbrook Park Leamington Spa Warwickshire CV34 6RS Tel: 01926 430481 Fax: 01926 882971
--	---	---	--	--

Made in England By: **Potterton Myson Limited**
Warwick Operations, Portobello Works, Emscote Road, Warwick CV34 5QU

All descriptions and illustrations provided in this leaflet have been carefully prepared but we reserve the right to make changes and improvements in our products which may affect the accuracy of the information contained in this leaflet.

POTTERTON MYSON
PART OF BLUE CIRCLE

All goods are sold subject to our standard conditions of sale which are available on request.

Registered Office: Myson House, Railway Terrace, Rugby, Warwickshire CV21 3JH. Registered No. 412935

Publication No. 559573/0195