

Glen Dimplex Boilers
Stoney Lane
Prescot
Merseyside. L35 2XW

For all telephone enquiries call:
0844 371 2222

website:
www.glendimplexboilers.com

Part of the Glen Dimplex Group

System 18 System 30

System Condensing Boilers



Installation and Servicing Instructions

Glen Dimplex Boilers is continually improving its products and therefore reserve the right to change product specifications without prior notice.
Errors & omissions excepted.

SALES AND SERVICE HELPLINE: 0844 371 1111

These instructions should be left with the user



GAS COUNCIL NUMBERS

Natural Gas

Dimplex System 18 - Gas Council Appliance No: **41 149 02**

Dimplex System 30 - Gas Council Appliance No: **41 149 01**



17.0 BENCHMARK



VENTED CYLINDER COMMISSIONING CHECKLIST

This Commissioning Checklist is to be completed in full by the competent person who commissioned the cylinder as a means of demonstrating compliance with the appropriate Building Regulations and should remain attached to the cylinder for future reference.

Failure to install and commission this equipment to the manufacturer's instructions may invalidate the warranty but does not affect statutory rights.

Commissioned by (print name) _____
 Company Name _____
 Company Address _____
 Telephone Number _____ Commissioning Date _____

To be completed by the customer on receipt of a Building Regulations Compliance Certificate:-
 Building Regulations Notification Number (if applicable) _____

ALL CYLINDERS

The vent pipe has been installed to BS6700/BS5449 Yes

What is the static head? _____ metres

Has an immersion heater been fitted? Yes No

If yes, does it have a non-auto resetting energy cut out? Yes No

Is the cold feed cistern supported in accordance with BS4213? Yes

Is the cylinder solar (or other renewable) compatible? Yes No

All appropriate pipes including the vent pipe have been insulated up to 1 metre or the point where they become concealed Yes

INDIRECT ONLY

A cylinder thermostat has been fitted in the recommended position Yes

The hot water is controlled by a programmer or time switch Yes

Is the system fully pumped? Yes No

Type of control system Y Plan S Plan Other

Commissioning Engineer's Signature _____
 Customer's Signature _____
 (To confirm satisfactory demonstration and receipt of manufacturer's literature)

*Where an installation is notifiable in England & Wales this will be made to Local Authority Building Control (LABC) either directly or through a Competent Persons Scheme. A Building Regulations Compliance Certificate will then be issued to the customer.

www.centralheating.co.uk

©Heating and Hotwater Industry Council (HHIC)

CONTENTS



SECTION	DESCRIPTION	PAGE
1.0	Introduction	4
2.0	Boiler Layout	7
3.0	Boiler Operation	8
4.0	Technical Data	9
5.0	Dimensions	10
6.0	System Details	11
7.0	Site Requirements	13
8.0	Flue options	17
9.0	Installation	21
10.0	Commissioning	25
11.0	Service Mode	27
12.0	Servicing & Maintenance	28
13.0	Changing Components	31
14.0	Electrical	39
15.0	Spare Parts	40
16.0	Error Codes	41
17.0	Benchmark	42
18.0	Warranty Terms & Conditions	46

18.0 WARRANTY TERMS & CONDITIONS

18.1 DIMPLEX 5YR WARRANTY

- Registration must be completed within 30 days of installation. Failure to return within 30 days will invalidate your warranty. Registration if effected by returning the enclosed registration card to the commercial center of Dimplex at 5 Spartan Close, Tachbrook Park, Leamington Spa, CV34 6RR. Proof of postage should be obtained.
- The Benchmark document must be completed by installer/householder at the time of installation and must be presented to our engineer at subsequent visits.
- The boiler must be serviced annually, at the householders expenses in accordance with manufacturer's instructions, and this service must be booked through Dimplex by calling 0844 371 1121
- The service must be carried out by a Dimplex approved central heating engineer. Any work carried out by a non-Dimplex approved engineer will invalidate this warranty.
- Appropriate system cleaning (e.g. power flush) and the correct use of additives must be carried out at the time of installation. Failure to cleanse the system will invalidate this warranty. Evidence of cleansing should be presented to our engineer upon request.
- This warranty applies only to manufacturing problems with the boiler; damage caused through misuse, incorrect operation, foreign bodies in the heating system, system faults and failures are not covered.
- This warranty applies only if the boiler is installed and used in accordance with the manufacturer's instructions, in normal domestic applications.
- Providing all the above Terms and Conditions are met, this warranty covers functional parts and labour.
- Dimplex offer the opportunity for a system audit and commissioning check within 30 days of registration. This is chargeable at the same rate as an annual service and if taken up then the first annual service will be provided free of charge. Failure to take up this offer may invalidate the full warranty which will revert to a standard 2 year warranty which will require an annual service in year 2 in any event.
- Failure to meet any of the above Terms and Conditions will invalidate this warranty.

1.0 INTRODUCTION**1.1 BUILDING REGULATIONS AND BENCHMARK CHECKLIST**

Building Regulations (England & Wales) require notification of the installation of a heating appliance to the relevant Local Authority Building Control Department.

From 1 April 2005 this can be achieved via a Competent Persons Self Certification Scheme as an option to notifying the Local Authority directly.

CORGI operates a Self Certification Scheme for gas heating appliances.

With the introduction of Self Certification Schemes, the Benchmark Logbook is being withdrawn. However, a similar document in the form of a commissioning checklist and service interval record is incorporated at the back of these instructions.

This company is a member of the Benchmark initiative and fully supports the aims of the programme. Its aim is to improve the standards of installation and commissioning of central heating systems in the UK and to encourage the regular servicing of all central heating systems to ensure safety and efficiency.

Building Regulations require that installations should comply with manufacturer's instructions. It is therefore important that the commissioning checklist is completed by the installer. The relevant section of Building Regulations only relates to dwellings. Therefore the checklist only applies if the appliance is being installed in a dwelling or some related structure.

1.2 INSTALLATION, COMMISSIONING, SERVICE & REPAIR

This appliance must be installed in accordance with the manufacturer's instructions and the regulations in force. Read the instructions fully before installing or using the appliance.

In GB, this must be carried out by a competent person as stated in the Gas Safety (Installation & Use) Regulations.

Definition of competence: A person who works for a CORGI registered company and holding current certificates in the relevant ACS modules, is deemed competent.

In IE, this must be carried out by a competent person as stated in I.S. 813 "Domestic Gas Installations"

No modifications or changes can be made to this appliance without prior written permission from Dimplex Boilers.

The manufacturer's instructions must not be taken as overriding any statutory requirements. If in doubt contact Dimplex Boilers on 0844 3711121.

Warning – Check the information on the data plate is compatible with local supply conditions.

All CORGI registered installers carry a CORGI identification card and have a registration number. You can check your installer is registered by telephoning 0870 4012300 or writing to:-

1 Elmwood
Chineham Business Park
Crockford Lane
Basingstoke
RG24 8WG

or check online at www.corgi-gas-safety.com

These appliances meet the requirements of:
Gas Appliance Directive 90/396/EEC
Efficiency of Hot Water Boilers Directive 92/42/EEC
Low Voltage Directive 92/42/EEC
Electromagnetic Compatibility Directive 92/31/EEC

Type test certified by:- Notified Body 0087 (Pin 87BT49).

Product/Production certified by:
Notified Body 0086.

For GB/IE only

17.0 BENCHMARK**SERVICE RECORD**

It is recommended that your hot water system is serviced regularly and that the appropriate Service Record is completed.

Service Provider

Before completing the appropriate Service Record below, please ensure you have carried out the service as described in the manufacturer's instructions.

SERVICE 1 Date _____

Engineer Name _____

Company Name _____

Telephone Number _____

Comments _____

Signature _____

SERVICE 2 Date _____

Engineer Name _____

Company Name _____

Telephone Number _____

Comments _____

Signature _____

SERVICE 3 Date _____

Engineer Name _____

Company Name _____

Telephone Number _____

Comments _____

Signature _____

SERVICE 4 Date _____

Engineer Name _____

Company Name _____

Telephone Number _____

Comments _____

Signature _____

SERVICE 5 Date _____

Engineer Name _____

Company Name _____

Telephone Number _____

Comments _____

Signature _____

SERVICE 6 Date _____

Engineer Name _____

Company Name _____

Telephone Number _____

Comments _____

Signature _____

SERVICE 7 Date _____

Engineer Name _____

Company Name _____

Telephone Number _____

Comments _____

Signature _____

SERVICE 8 Date _____

Engineer Name _____

Company Name _____

Telephone Number _____

Comments _____

Signature _____

SERVICE 9 Date _____

Engineer Name _____

Company Name _____

Telephone Number _____

Comments _____

Signature _____

SERVICE 10 Date _____

Engineer Name _____

Company Name _____

Telephone Number _____

Comments _____

Signature _____

17.0 BENCHMARK



MAINS PRESSURE HOT WATER STORAGE SYSTEM COMMISSIONING CHECKLIST

This Commissioning Checklist is to be completed in full by the competent person who commissioned the storage system as a means of demonstrating compliance with the appropriate Building Regulations and then handed to the customer to keep for future reference.

Failure to install and commission this equipment to the manufacturer's instructions may invalidate the warranty but does not affect statutory rights.

Customer Name _____ Telephone Number _____
 Address _____
 Cylinder Make and Model _____
 Cylinder Serial Number _____
 Commissioned by (*print name*) _____ Registered Operative ID Number _____
 Company Name _____ Telephone Number _____
 Company Address _____
 Commissioning Date _____

To be completed by the customer on receipt of a Building Regulations Compliance Certificate*:

Building Regulations Notification Number (*if applicable*) _____

ALL SYSTEMS PRIMARY SETTINGS (indirect heating only)

Is the primary circuit a sealed or open vented system? Sealed Open
 What is the maximum primary flow temperature? _____ °C

ALL SYSTEMS

What is the incoming static cold water pressure at the inlet to the system? _____ bar
 Has a strainer been cleaned of installation debris (if fitted)? Yes No
 Is the installation in a hard water area (above 200ppm)? Yes No
 If yes, has a water scale reducer been fitted? Yes No
 What type of scale reducer has been fitted? _____
 What is the hot water thermostat set temperature? _____ °C
 What is the maximum hot water flow rate at set thermostat temperature (measured at high flow outlet)? _____ l/min
 Time and temperature controls have been fitted in compliance with Part L of the Building Regulations? Yes
 Type of control system (if applicable) Y Plan S Plan Other
 Is the cylinder solar (or other renewable) compatible? Yes No
 What is the hot water temperature at the nearest outlet? _____ °C
 All appropriate pipes have been insulated up to 1 metre or the point where they become concealed Yes

UNVENTED SYSTEMS ONLY

Where is the pressure reducing valve situated (if fitted)? _____
 What is the pressure reducing valve setting? _____ bar
 Has a combined temperature and pressure relief valve and expansion valve been fitted and discharge tested? Yes No
 The tundish and discharge pipework have been connected and terminated to Part G of the Building Regulations Yes
 Are all energy sources fitted with a cut out device? Yes No
 Has the expansion vessel or internal air space been checked? Yes No

THERMAL STORES ONLY

What store temperature is achievable? _____ °C
 What is the maximum hot water temperature? _____ °C

ALL INSTALLATIONS

The hot water system complies with the appropriate Building Regulations Yes
 The system has been installed and commissioned in accordance with the manufacturer's instructions Yes
 The system controls have been demonstrated to and understood by the customer Yes
 The manufacturer's literature, including Benchmark Checklist and Service Record, has been explained and left with the customer Yes

Commissioning Engineer's Signature _____

Customer's Signature _____
 (*To confirm satisfactory demonstration and receipt of manufacturer's literature*)

*All installations in England and Wales must be notified to Local Authority Building Control (LABC) either directly or through a Competent Persons Scheme. A Building Regulations Compliance Certificate will then be issued to the customer.



1.0 INTRODUCTION



1.3 LEGISLATION

The appliance is suitable only for installation in GB and IE and should be installed in accordance with the rules in force, and only used in a suitably ventilated location.

In GB, the installation must be carried out by a CORGI Registered Installer. It must be carried out in accordance with the relevant requirements of the:

- Gas Safety (Installation & Use) Regulations.
- The appropriate Building Regulations either The Building regulations, The Building Regulations (Scotland), Building Regulations (Northern Ireland).
- The Water Fittings Regulations or Water Byelaws in Scotland.
- The Current I.E.E. Wiring Regulations.

Where no specific instructions are given, reference should be made to the relevant British Standard Code of Practice.

In IE, the installation must be carried out by a competent Person and installed in accordance with the current edition of I.S. 813 'Domestic Gas Installations', the current Building Regulations and reference should be made to the current ETCI rules for electrical installation.

All systems must be thoroughly flushed and treated with inhibitor (see section 6.2).

Codes of Practice – refer to the most recent version

In GB the following Codes of Practice apply:

Standard	Scope
BS 7967	Carbon monoxide in dwellings and the combustion performance of gas fired appliances
BS 7967-2	Guide for using electronic portable combustion gas analysers in the measurement of carbon monoxide and the determination of combustion performance
BS 7967-3	Guide for responding to measurements obtained from electronic portable combustion gas analysers
BS 7967-4	Guide for using electronic portable combustion gas analysers as part of the process of servicing and maintenance of gas fired appliances
BS 6891	Gas installation
BS 5546	Installation of hot water supplies for domestic purposes
BS 5449	Forced circulation hot water systems
BS 6798	Installation of gas fired hot water boilers
BS 5440 Part 1	Flues
BS 5440 Part 2	Ventilation
BS 7074	Expansion vessels and ancillary equipment for sealed water systems
BS 7593	Treatment of water in domestic hot water central heating systems

In IE the following Codes of Practice apply:

Standard	Scope
I.S. 813	Domestic Gas Installation
The following standards give valuable additional information:	
BS 5546	Installation of hot water supplies for domestic purposes
BS 5449	Forced circulation hot water systems
BS 7074	Expansion vessels and ancillary equipment for sealed water systems
BS 7593	Treatment of water in domestic hot water central heating systems

GAS LEAKS

**DO NOT OPERATE ANY ELECTRICAL SWITCHES, OR USE A NAKED FLAME. TURN OFF THE GAS SUPPLY. VENTILATE THE AREA BY OPENING DOORS AND WINDOWS. CALL OUT YOUR LOCAL GAS SUPPLIER
 TEL: 0800 111 999**

Control of Substances Hazardous to Health

Under Section 6 of the Health and Safety at Work Act 1974, it is required to provide information on substances hazardous to health.

The adhesives and sealants used in this appliance are cured and give no known hazard in this state.

Insulation Pads - These can cause irritation to skin, eye and respiratory tract. If you have a history of skin complaint you may be susceptible to irritation. High dust levels are usual only if the material is broken. Normal handling should not cause discomfort, but follow normal good hygiene and wash your hands before eating, drinking or going to the lavatory. If you do suffer irritation to the eyes or severe irritation to the skin seek medical attention.

Gas and Electricity Consumer Council (Energywatch)

Energywatch is an independent organisation, which protects the interests of gas users. If you need advice concerning energy issues, they may be contacted on their consumer help line number: 08459 060708, or via their website; www.energywatch.org.uk.

This appliance is not intended for use by persons (including children) with reduced physical, sensory or mental capabilities, or lack of experience and knowledge, unless they have been given supervision or instructions concerning use of the appliance by a person responsible for their safety. Children should be supervised to ensure that they do not play with the appliance.

1.0 INTRODUCTION**1.4 SAFE MANUAL HANDLING**

- The boiler should be handled and lifted by two people. Wear appropriate Personal Protection Equipment e.g. protective gloves, safety footwear etc. Plan your route to minimise the number of turns needed to handle/lift the boiler.
- Where possible transport the boiler using a sack truck or other suitable trolley. Try to avoid steps, wet or slippery surfaces, unlit areas etc. and take special care on ladders/intro lofts.
- When handling or lifting always use safe techniques - keep your back straight, bend your knees. Don't twist - move your feet, avoid bending forwards and sideways and keep the load as close to your body as possible.
- Asses the risks associated with handling and lifting according to the conditions on site. If in doubt seek advice before proceeding. Health and Safety is the responsibility of everyone.

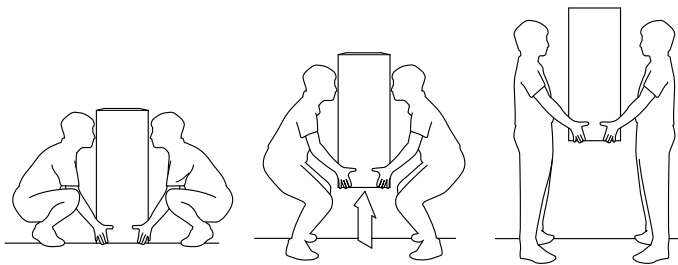
**1.5 DESCRIPTION**

1. The appliances incorporate a microprocessor based, fully modulating air/gas ratio control system with direct burner ignition. This provides a modulated heat output, with internal frost protection provided as standard. The heat exchanger is constructed from stainless steel encased in high temperature polymer.

A combined circulating pump, automatic air vent assembly, pressure gauge, safety valve and system expansion vessel are included.

Isolation valves are fitted to the service connections.

The boiler has a pump over run feature therefore the central heating system must include either a proprietary automatic bypass valve or a radiator must be fitted with lock shield valves. A separate CH expansion vessel is not required if the total CH system content is less than 84 litres. However one is required for systems with volumes greater than 84 litres; refer to section 6.5. It is recommended that a drain cock is fitted at the lowest point in the system.

- The boiler is designed for use on Natural Gas (G20). A natural gas to propane conversion kit is available for each Dimplex System Boiler.
- The boiler is suitable for use only on fully pumped sealed heating systems.
- The boiler data badge gives details of the model, serial number and Gas Council number and is situated on the inner door panel. It is visible when the case front is removed. (Fig. 1)
- The boiler model name and serial number are also shown on the information label on the inside of the fascia. This is for user reference.
- The boiler is intended to be installed in residential / commercial / light industrial E.M.C. environments on a governed meter supply only.
- The boiler must be installed with one of the purpose designed flues such as the standard horizontal telescopic flue kit, part no. 956120.
- All systems must be thoroughly flushed and treated with inhibitor (see section 6.2).**

1.6 OPTIONAL EXTRAS

RF room thermostats etc. are available as optional extras, however if an external control is fitted the hole in the fascia must be covered using the fascia blanking panel supplied (Part No. 300635)

1.7 PACK CONTENTS

- Boiler
- Wall fixing jig
- Templates & 'Quick Fit' Guide
- Literature Pack
- Plugs and screws

17.0 BENCHMARK**SERVICE RECORD**

It is recommended that your heating system is serviced regularly and that the appropriate Service Record is completed.

Service Provider

Before completing the appropriate Service Record below, please ensure you have carried out the service as described in the manufacturer's instructions.

Always use the manufacturer's specified spare part when replacing controls.

SERVICE 1 Date _____

Energy Efficiency Checklist completed? Yes No

Engineer Name _____

Company Name _____

Telephone Number _____

CORGI ID Number _____

Comments _____

Signature _____

SERVICE 2 Date _____

Energy Efficiency Checklist completed? Yes No

Engineer Name _____

Company Name _____

Telephone Number _____

CORGI ID Number _____

Comments _____

Signature _____

SERVICE 3 Date _____

Energy Efficiency Checklist completed? Yes No

Engineer Name _____

Company Name _____

Telephone Number _____

CORGI ID Number _____

Comments _____

Signature _____

SERVICE 4 Date _____

Energy Efficiency Checklist completed? Yes No

Engineer Name _____

Company Name _____

Telephone Number _____

CORGI ID Number _____

Comments _____

Signature _____

SERVICE 5 Date _____

Energy Efficiency Checklist completed? Yes No

Engineer Name _____

Company Name _____

Telephone Number _____

CORGI ID Number _____

Comments _____

Signature _____

SERVICE 6 Date _____

Energy Efficiency Checklist completed? Yes No

Engineer Name _____

Company Name _____

Telephone Number _____

CORGI ID Number _____

Comments _____

Signature _____

SERVICE 7 Date _____

Energy Efficiency Checklist completed? Yes No

Engineer Name _____

Company Name _____

Telephone Number _____

CORGI ID Number _____

Comments _____

Signature _____

SERVICE 8 Date _____

Energy Efficiency Checklist completed? Yes No

Engineer Name _____

Company Name _____

Telephone Number _____

CORGI ID Number _____

Comments _____

Signature _____

SERVICE 9 Date _____

Energy Efficiency Checklist completed? Yes No

Engineer Name _____

Company Name _____

Telephone Number _____

CORGI ID Number _____

Comments _____

Signature _____

SERVICE 10 Date _____

Energy Efficiency Checklist completed? Yes No

Engineer Name _____

Company Name _____

Telephone Number _____

CORGI ID Number _____

Comments _____

Signature _____

17.0 BENCHMARK



GAS BOILER SYSTEM COMMISSIONING CHECKLIST

This Commissioning Checklist is to be completed in full by the competent person who commissioned the boiler as a means of demonstrating compliance with the appropriate Building Regulations and then handed to the customer to keep for future reference.

Failure to install and commission this equipment to the manufacturer's instructions may invalidate the warranty but does not affect statutory rights.

Customer Name _____ Telephone Number _____
 Address _____
 Boiler Make and Model _____
 Boiler Serial Number _____
 Commissioned by (print name) _____ CORGI ID Number _____
 Company Name _____ Telephone Number _____
 Company Address _____
 Commissioning Date _____

To be completed by the customer on receipt of a Building Regulations Compliance Certificate*:
 Building Regulations Notification Number (if applicable) _____

CONTROLS Tick the appropriate boxes

Time and Temperature Control to Heating	Room Thermostat and Programmer/Timer <input type="checkbox"/>	Programmable Room Thermostat <input type="checkbox"/>	Load/Weather Compensation <input type="checkbox"/>	Optimum Start Control <input type="checkbox"/>
Time and Temperature Control to Hot Water	Cylinder Thermostat and Programmer/Timer <input type="checkbox"/>		Combination Boiler <input type="checkbox"/>	
Heating Zone Valves	Fitted <input type="checkbox"/>		Not Required <input type="checkbox"/>	
Hot Water Zone Valves	Fitted <input type="checkbox"/>		Not Required <input type="checkbox"/>	
Thermostatic Radiator Valves	Fitted <input type="checkbox"/>		Not Required <input type="checkbox"/>	
Automatic Bypass to System	Fitted <input type="checkbox"/>		Not Required <input type="checkbox"/>	
Boiler Interlock			Provided <input type="checkbox"/>	

ALL SYSTEMS

The system has been flushed and cleaned in accordance with BS7593 and boiler manufacturer's instructions Yes
 What system cleaner was used? _____
 What inhibitor was used? _____ Quantity _____ litres

CENTRAL HEATING MODE Measure and Record:

Gas Rate _____ m³/hr OR _____ ft³/hr
 Burner Operating Pressure (if applicable) _____ mbar OR Gas Inlet Pressure _____ mbar
 Central Heating Flow Temperature _____ °C
 Central Heating Return Temperature _____ °C

COMBINATION BOILERS ONLY

Is the installation in a hard water area (above 200ppm)? Yes No
 If yes, has a water scale reducer been fitted? Yes No
 What type of scale reducer has been fitted? _____

DOMESTIC HOT WATER MODE Measure and Record:

Gas Rate _____ m³/hr OR _____ ft³/hr
 Burner Operating Pressure (at maximum rate) _____ mbar OR Gas Inlet Pressure (at maximum rate) _____ mbar
 Cold Water Inlet Temperature _____ °C
 Hot water has been checked at all outlets Yes Temperature _____ °C
 Water Flow Rate _____ l/min

CONDENSING BOILERS ONLY

The condensate drain has been installed in accordance with the manufacturer's instructions and/or BS5546/BS6798 Yes

ALL INSTALLATIONS

If required by the manufacturer, record the following CO₂ _____ % OR CO _____ ppm OR CO/CO₂ Ratio _____
 The heating and hot water system complies with the appropriate Building Regulations Yes
 The boiler and associated products have been installed and commissioned in accordance with the manufacturer's instructions Yes
 The operation of the boiler and system controls have been demonstrated to and understood by the customer Yes
 The manufacturer's literature, including Benchmark Checklist and Service Record, has been explained and left with the customer Yes

Commissioning Engineer's Signature _____
 Customer's Signature _____
 (To confirm satisfactory demonstration and receipt of manufacturer's literature)

*All installations in England and Wales must be notified to Local Authority Building Control (LABC) either directly or through a Competent Persons Scheme. A Building Regulations Compliance Certificate will then be issued to the customer.



www.centralheating.co.uk

2.0 BOILER LAYOUT



2.1 KEY

1. Expansion Vessel
2. Automatic Air Vent
3. Circulation Pump
4. Drain Off Point
5. Pressure Relief Valve
6. Central Heating System Pressure Gauge
7. PCB
8. Control Box
9. Flexible condensate pipe assembly
10. Flame Sensing Electrode
11. Spark Electrode
12. Primary Heat Exchanger
13. Fan Assembly
14. Gas Valve & Swirl Plate Assembly
15. Reset Button
16. Central Heating Temperature Control
17. Air / Gas Channel
18. Burner & Burner Door
19. Spark Generator
20. Data Badge
21. Flue Sample Point
22. Manual Air Vent
23. Burner On Light

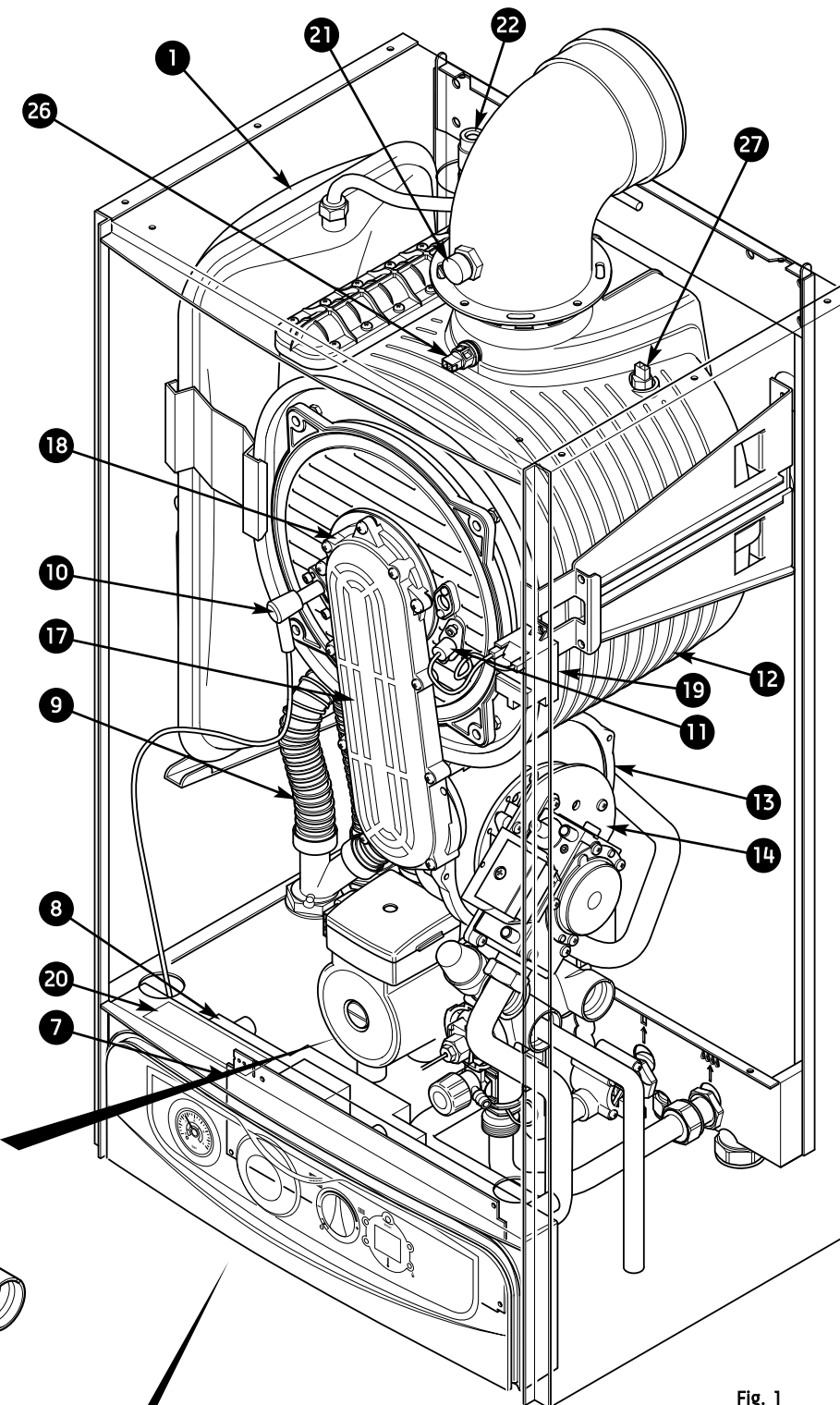
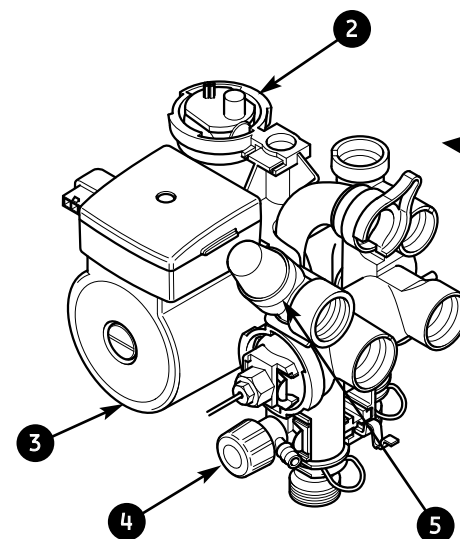

Fig. 1



24. Central Heating Mode Light
25. Display
26. Flue Thermistor
27. Thermal Fuse

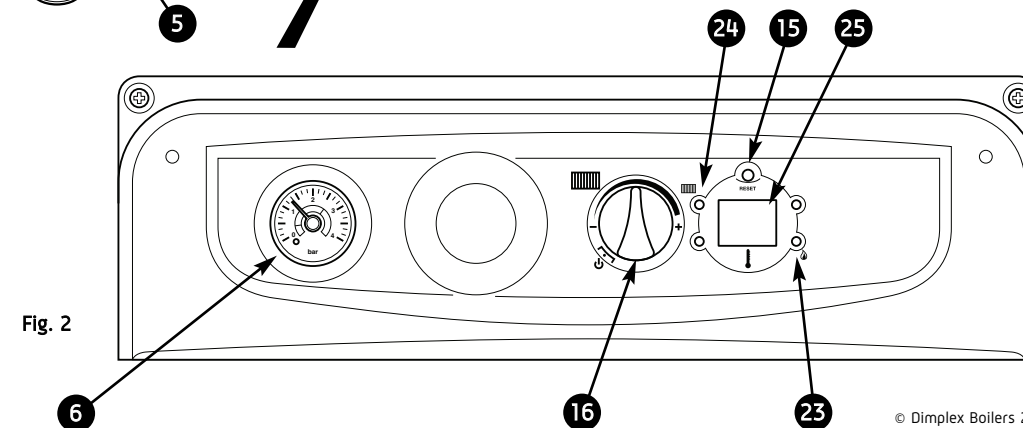

Fig. 2

3.0 BOILER OPERATION



3.1 CENTRAL HEATING

1. With a demand for heating, the pump, circulates water through the primary circuit.

2. Once the main burner ignites the fan speed controls the gas rate to maintain the heating temperature measured by the temperature sensors.

3. When the demand is satisfied the burner is extinguished and a 5 minute delay occurs before the burner will re-light (anti-cycling), the pump continues to run for a period of 2 minutes (Pump Overrun).

3.2 FROST PROTECTION MODE

1. Providing there is mains power supply to the appliance, the frost protection mode is integral.
If the system temperature falls below 5°C then the boiler will fire on its minimum setting until a flow temperature of 20°C is reached. Further protection can be incorporated by using a system frost thermostat.

3.3 PUMP PROTECTION

1. The pump will automatically operate for 1 minute in every 24 hours to prevent sticking.

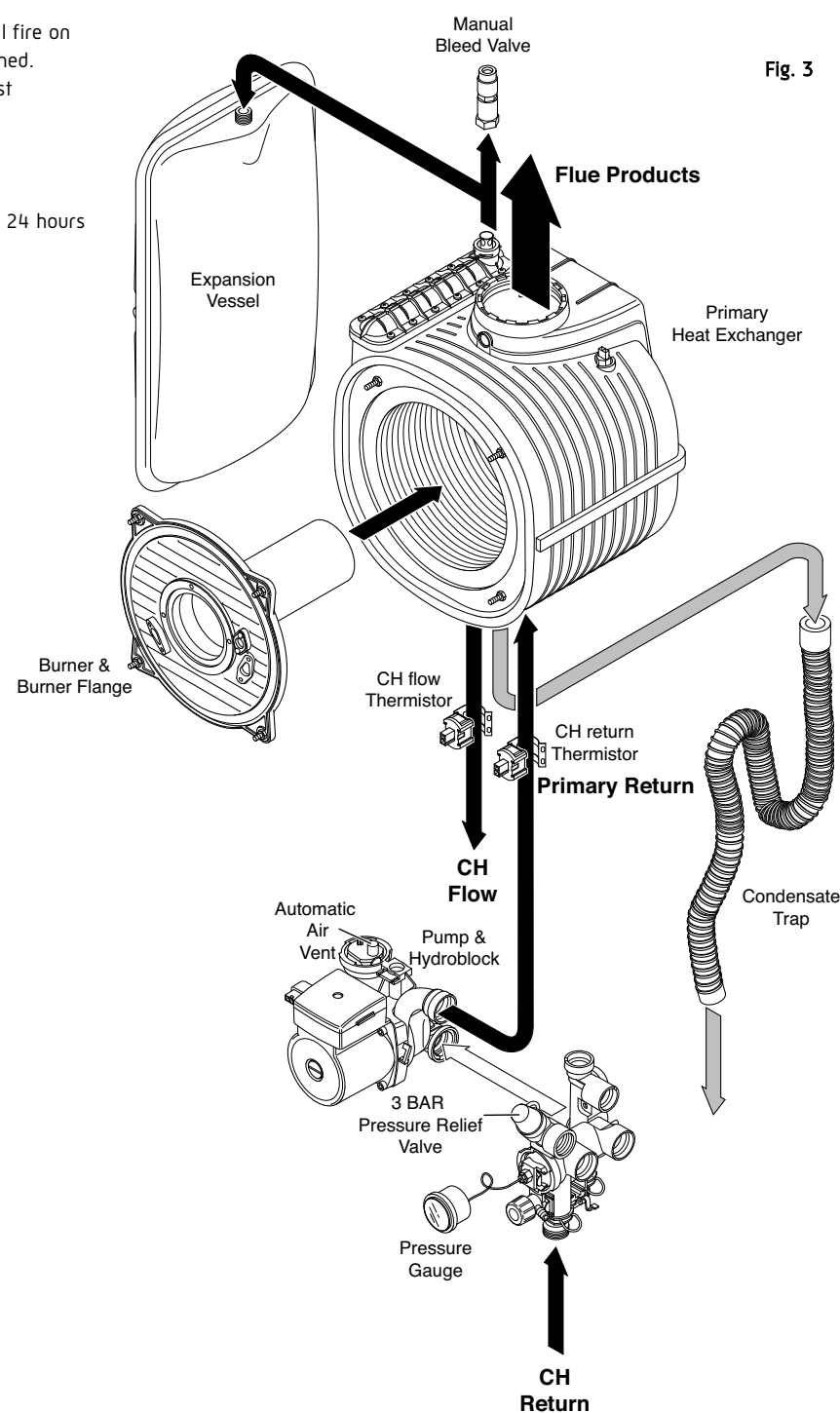

Fig. 3

16.0 ERROR CODES



The boiler is in an ERROR state when there is an error code flashing on the back lit display.

CH = Central Heating BCC = Boiler Chip Card

Press and release the RESET button, the control tries to initiate a restart if possible

ERROR CODE	DESCRIPTION	REASON	ACTION	RESET POSSIBLE
1	Overheated appliance	CH Water temperature greater than 105°C	<ul style="list-style-type: none"> •Check no air is in heat exchanger/CH system •Check plate heat exchanger for blockages •Check CH thermistor •Check system bypass is functional 	Y
4	No flame	No flame signal on ignition	<ul style="list-style-type: none"> •Check detection electrode/lead – electrode may require cleaning •Check spark gap •Check gas supply & pressure •Check flue system is connected properly •Check condensate trap not blocked •Check gas valve and/or lead 	Y
5	Flame loss	Loss of flame signal during operation	<ul style="list-style-type: none"> •Check detection electrode/lead •Check gas valve mains lead 	Y
6	Temporarily overheated appliance	Water temperature greater than 95°C	<ul style="list-style-type: none"> •Check overheat thermostat •Check no air is in heat exchanger/CH system •CH system and hot water plate heat exchanger blockage •Check CH thermistor •Check system bypass is functional 	Auto Re-start after 1 minute
7	Overheated appliance	Flue over temperature > 92°C	<ul style="list-style-type: none"> •Check no air in heat exchanger •Check flue thermistor •Check flue system •Check pump •Check PCB/X8 connector 	Y
11	Flame simulation	Flame detected when gas valve closed	<ul style="list-style-type: none"> •Check detection electrode/lead electrode may require cleaning •Check gas valve operation. 	Y
12	No ignition	CH Flow thermistor failure	<ul style="list-style-type: none"> •Check CH flow thermistor – open circuit •Check PCB/X6 connector – open circuit 	Auto Re-start when fixed
13	No flame	Flue thermistor failure	<ul style="list-style-type: none"> •Check PCB/X8 connector •Check flue thermistor •Check thermal fuse – open circuit 	Auto Re-start when fixed
16	No ignition	CH Return thermistor failure	<ul style="list-style-type: none"> •Check CH return thermistor – open circuit •Check PCB/X6 connector – open circuit 	Auto Re-start when fixed
20	No flame	Gas valve V1-V2 failure	<ul style="list-style-type: none"> •Check/replace gas valve •Check gas valve harness •Check PCB/X2A 	Y
24	Faulty fan signal, no flame and fan runs continuously	Missing or defective signal from fan.	<ul style="list-style-type: none"> •Check fan operation •Check fan connection •Check PCB/X3 connector •Check flue condition 	Y
32	No flame	Power supply failure	<ul style="list-style-type: none"> •Check mains supply voltage to boiler •Check all PCB connectors 	Auto Re-start when fixed
34	CRC Error / No flame	Incorrect BCC	<ul style="list-style-type: none"> •Replace correct BCC (BCC's only fitted to replacement PCB's) 	Auto Re-start when fixed
35	BCC Error / No flame	Incorrect/missing BCC	<ul style="list-style-type: none"> •Reset or replace BCC (BCC's only fitted to replacement PCB's) 	Auto Re-start when fixed
36	BCC Error / No flame	Damaged BCC	<ul style="list-style-type: none"> •Replace BCC (BCC's only fitted to replacement PCB's) 	Auto Re-start when fixed
37	BCC Error / No flame	Different BCC	<ul style="list-style-type: none"> •BCC and PCB software incompatible, replace BCC (BCC's only fitted to replacement PCB's) 	Auto Re-start when fixed
38	BCC Error / No flame	Different BCC	<ul style="list-style-type: none"> •Reset the appliance in accordance with BCC fitting instructions (BCC's only fitted to replacement PCB's) 	Auto Re-start when fixed
39	BCC Error / No flame	BCC installation failed	<ul style="list-style-type: none"> •Refit BCC in accordance with BCC fitting instructions (BCC's only fitted to replacement PCB's) 	Auto Re-start when fixed
41	Water flow failure/ Flame for a short period only	Low water pressure Reversed sensors	<ul style="list-style-type: none"> •Check CH flow circulation •Check water pressure(> 0.5 bar) •Check pump/lead •Check expansion vessel •Check flow and return sensors connected correct way around 	Y
42	Water flow failure/ Flame for a short period only	Low water pressure No flow Dry run protection	<ul style="list-style-type: none"> •Check no air in heat exchanger •Check CH flow circulation •Check water pressure(> 0.5 bar) •Check pump/lead •Check expansion vessel 	Y
50	BCC Error / No flame	BCC Activation	<ul style="list-style-type: none"> •Press reset to activate BCC (BCC's only fitted to replacement PCB's) 	Y
(No display)	No light indication	Defective power supply	<ul style="list-style-type: none"> •Check power supply •Check PCB/X1B connector •Check PCB fuse 	Auto Re-start when fixed

15.0 SPARE PARTS



15.1 SHORT PARTS LIST

Key	GC Number	Description	QTY	Pt. No.
1	H29-740	Electrode - Ignition c/w Gasket	1	988526
2	H38-213	Detection Electrode c/w Gasket	1	988540
3	H29-236	Spark Generator c/w Lead	1	500665
4	TBA	System 18 & 30 gas control valve assembly NG	1	988660
5	H38-215	Fan Assembly	1	601016
6a	H29-172	Burner (System 18)	1	700600
6b	TBA	Burner (System 30)	1	700602
7	TBA	Burner Door Insulation	1	352671
8a	H38-217	Heat Exchanger (System 18)	1	451101
8b	TBA	Heat Exchanger (System 30)	1	451151
9	H29-202	Pump Head 6m	1	500672
11	H29-237	Expansion Vessel	1	451020
12	TBA	3 Bar Pressure Relief valve	1	500751
13	H29-213	Water Temperature sensor	2	500661
14	H38-219	Flue Thermistor	1	500662
16	E23-541	Pressure Gauge 4bar	1	450961
17	TBA	Auto Air Vent	1	500752
18a	TBA	Dimplex System 18 NG PCB Kit	1	988663
18b	TBA	Dimplex System 30 NG PCB Kit	1	988583
22	H29-179	Valve - Manual Bleed	1	300730
23	H38-226	Heat Exchanger seal & Clip Kit	1	988546
24	H29-208	Hydroblock - O-Ring and Clip	1	988669
25	TBA	Hydroblock Manual bleed cock	1	500708

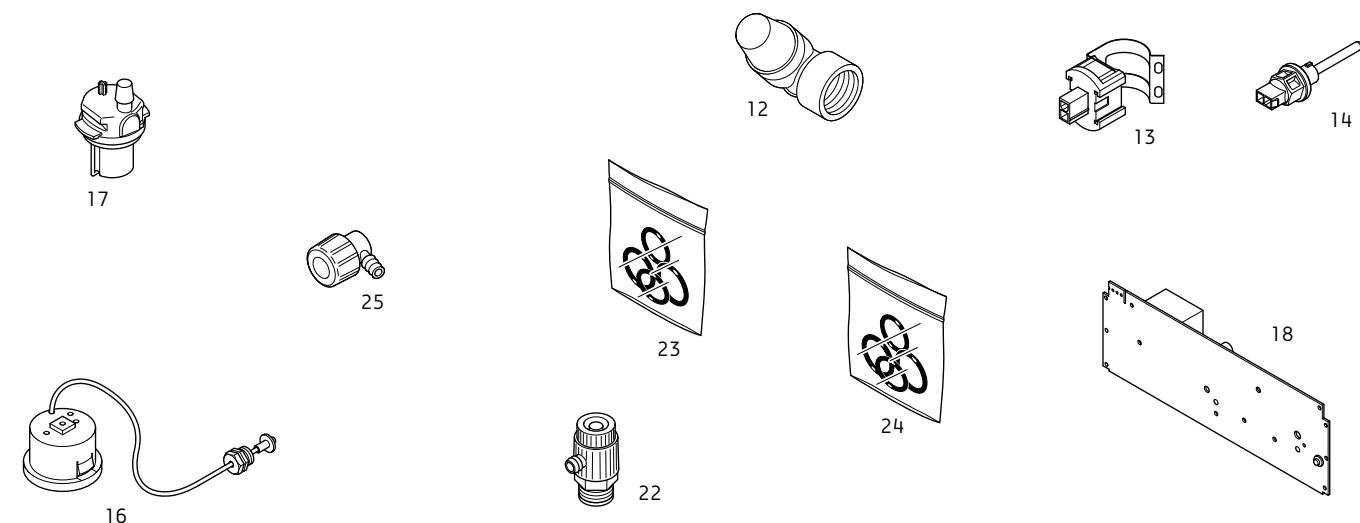
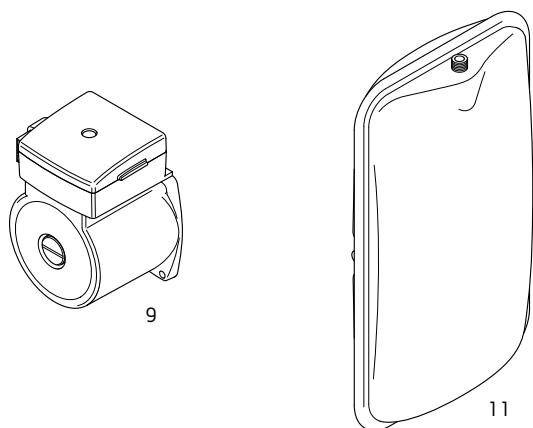
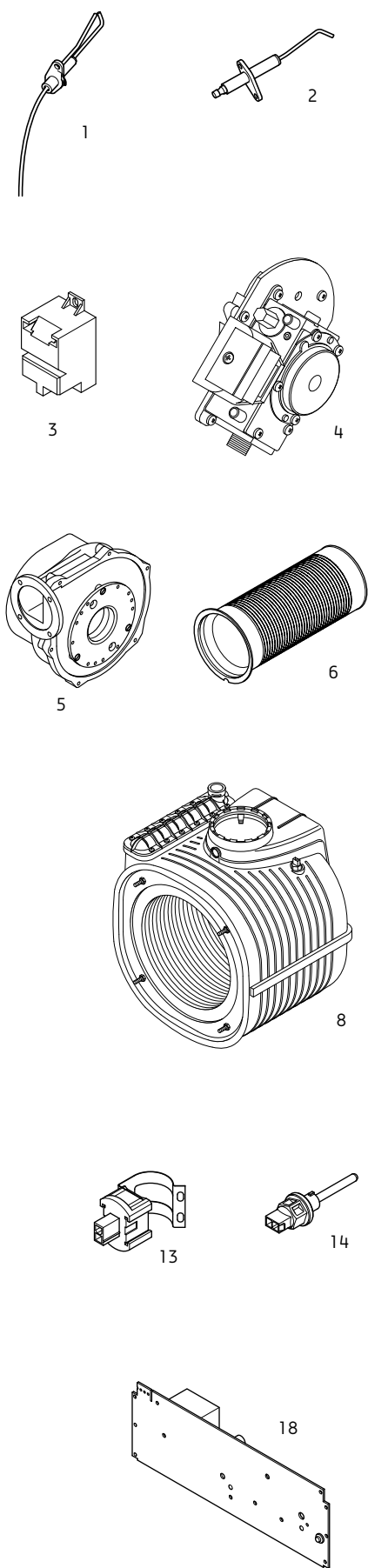

4.0 TECHNICAL DATA



4.1 PERFORMANCE DATA

Appliance Classification C13, C33, C53, B23			System 18	System 30
Mode	Rate			
Output (non-condensing)(80-60°C)	Max	kW	18.1	29.8
	Min	kW	6.0	8.1
Output (condensing)(50-30°C)	Max	kW	19.7	32.5
Input Max Rate	Net	kW	18.4	30.4
	Gross	kW	20.4	33.7
Input Min Rate	Net	kW	5.4	7.6
	Gross	kW	6.0	8.4
Gas Rate (after 10 min operation - hot)	Max	m ³ /h	1.95	3.2
Seasonal Efficiency		%	90.3	90.3
Seasonal Efficiency (SEDBUK)		Band	"A"	"A"
Nox Classification		Class	"5"	"5"
Min System Pressure		Bar	0.5	0.5
Max System Pressure		Bar	2.5	2.5
Max Central Heating Flow Temperature		°C	80	80
Min Central Heating Flow Temperature		°C	30	30
General Specifications				
Max lift weight		kg	33.6	39.6
Total water capacity		Ltr	1.8	3.1
Integral expansion vessel capacity		Ltr	8	8
Maximum heating system water content using fitted expansion vessel, @ 0.75 bar		Ltr	84	84
Electrical supply			240V 50Hz	Fuse at 3A
Internal fuse			T4H 4A 250V	
Maximum power consumption		W	100	125
IP Rating			IPX4	IPX4
Flue gas temperature 80/60		°C	59	75
Flue gas temperature 50/30		°C	41	55
CO: value max rate (Nat Gas) (Case must be fitted when taking reading)		%	8.8-9.2	8.8-9.2
CO: value min rate (Nat Gas) (Case must be fitted when taking reading)		%	8.5-8.9	8.7-9.1
CO value max rate (Propane) (Case must be fitted when taking reading)		P.P.M	15-60	15-60
CO value min rate (Propane) (Case must be fitted when taking reading)		P.P.M	0-40	0-40
CO: value max rate (Propane) (Case must be fitted when taking reading)		%	10.8-11.2	10.5-10.9
CO: value min rate (Propane) (Case must be fitted when taking reading)		%	10.4-10.8	10.3-10.7
CO value max rate (Propane) (Case must be fitted when taking reading)		P.P.M	80-160	80-160
CO value min rate (Propane) (Case must be fitted when taking reading)		P.P.M	0-40	0-40
Gas Pressure - Natural Gas		mbar	18-20	18-20
Gas Pressure - Propane		mbar	37	37
Connections				
Gas			22 mm compression	
CH flow			22 mm compression	
CH return			22 mm compression	
Pressure relief valve outlet			15 mm compression	
Condensate Drain			21.5 - 22 mm plastic overflow pipe	
P.P.M = Parts Per Million				

5.0 DIMENSIONS



Fig. 4

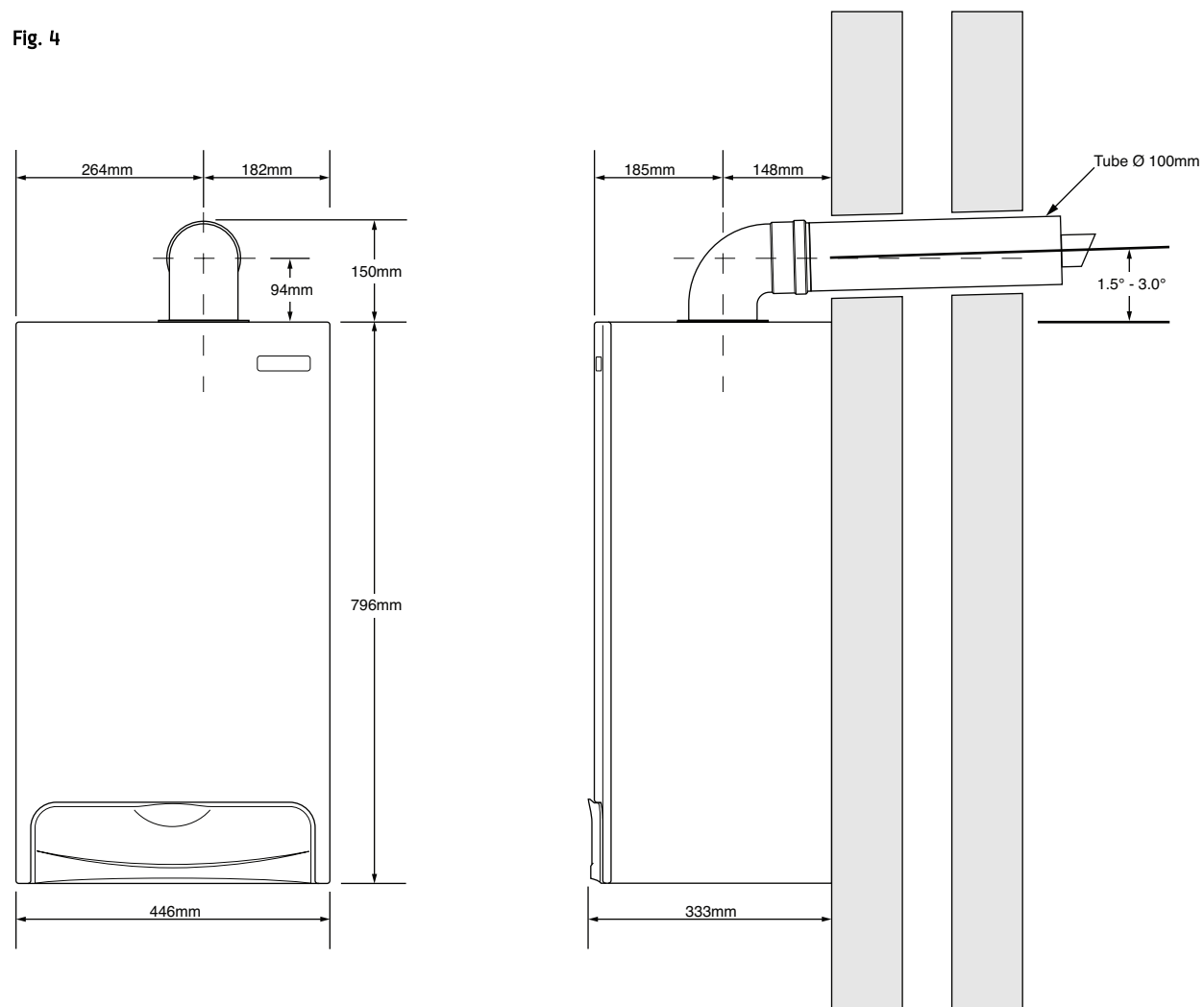
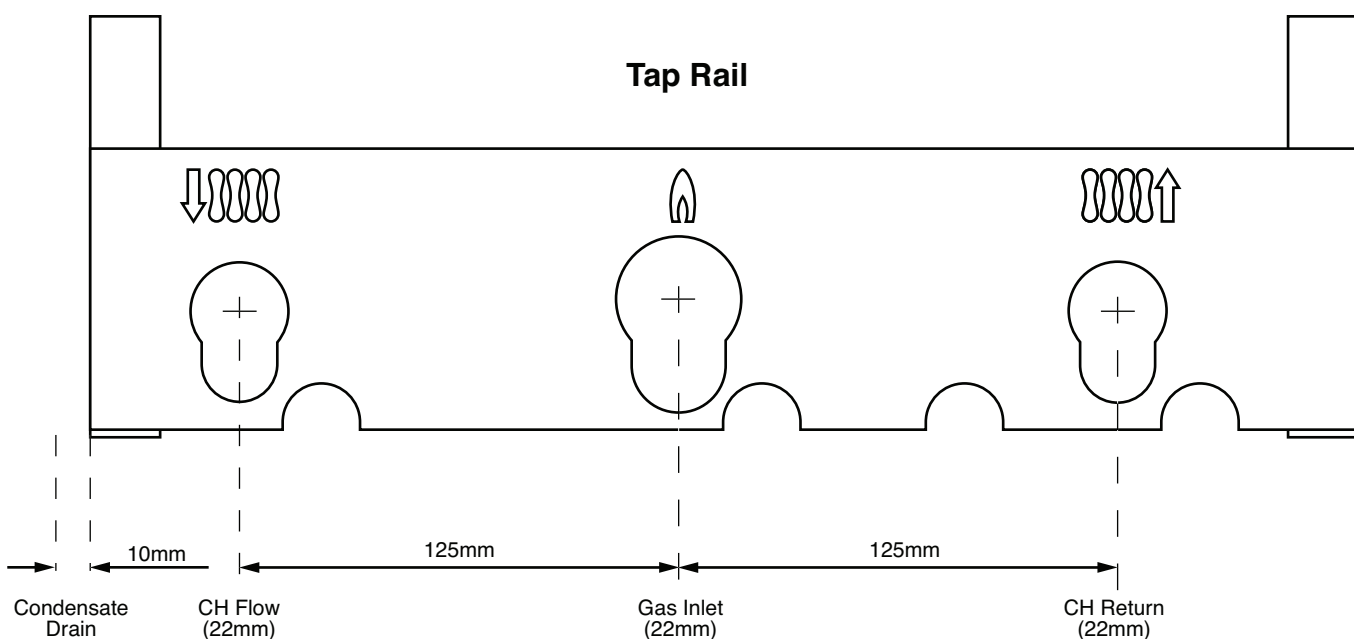

Fig. 5



14.0 ELECTRICAL



14.1 ILLUSTRATED WIRING DIAGRAM

Key - Cable Colours

- g Green
- y Yellow
- b Blue
- r Red
- bk Black
- o Orange
- g/y Green / Yellow
- br Brown
- gr Grey
- w White

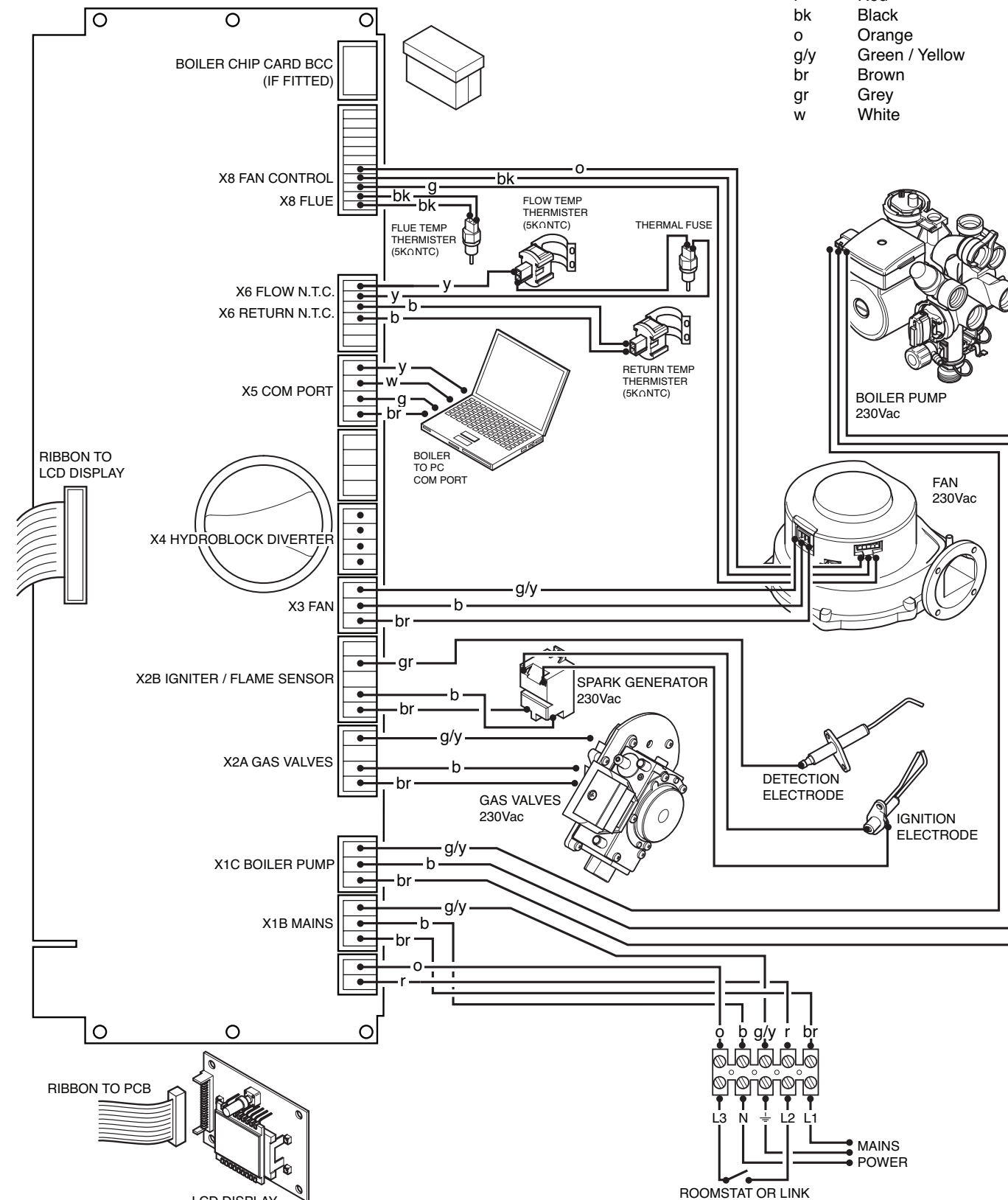

13.0 CHANGING COMPONENTS**13.18 PCB**

1. Ensure supply voltage is fully isolated.
2. Undo the screws holding the control box and gently ease the box forward (Fig. 69).
3. Locate the retaining bars on the top of the fascia and unclip them from the control box.
4. Unclip the PCB from the plastic control box.
5. Note the positions of all the connections on the PCB and disconnect them.
(DO NOT REMOVE THE YELLOW BCC (Fig. 69))
6. Carefully unclip and remove the ribbon cable from the PCB and withdraw.
7. Fit all the connection plugs to the new PCB including the ribbon cable, take care not to damage the PCB.
8. Unless specifically instructed **NOT** to do so by the Dimplex Service Department, always fit the new BCC if supplied with the replacement PCB.

NOTE: Always double check the label on the BCC card to ensure it is the correct BCC for the boiler model to which it is being fitted.
NEVER FIT AN INCORRECT BCC.

9. Reassemble in reverse order, ensuring that the control knob are reset to their previous positions

13.19 BCC

1. Ensure supply voltage is fully isolated.
2. Dismantle the control box as described above to gain access to the PCB (Fig. 69).
3. Note the orientation of the existing BCC (if fitted) and carefully remove by sliding it off the edge of the PCB.
4. Re-fit the new BCC by sliding it onto the edge of the PCB, ensuring the orientation is correct.

NOTE: Always double check the label on the BCC card to ensure it is the correct BCC for the boiler model to which it is being fitted.
NEVER FIT AN INCORRECT BCC.

5. Reassemble as above.
6. Power up boiler, and briefly press the reset button, wait for at least 5 seconds and then briefly press the reset button again.
7. The boiler should now be checked for correct operation.

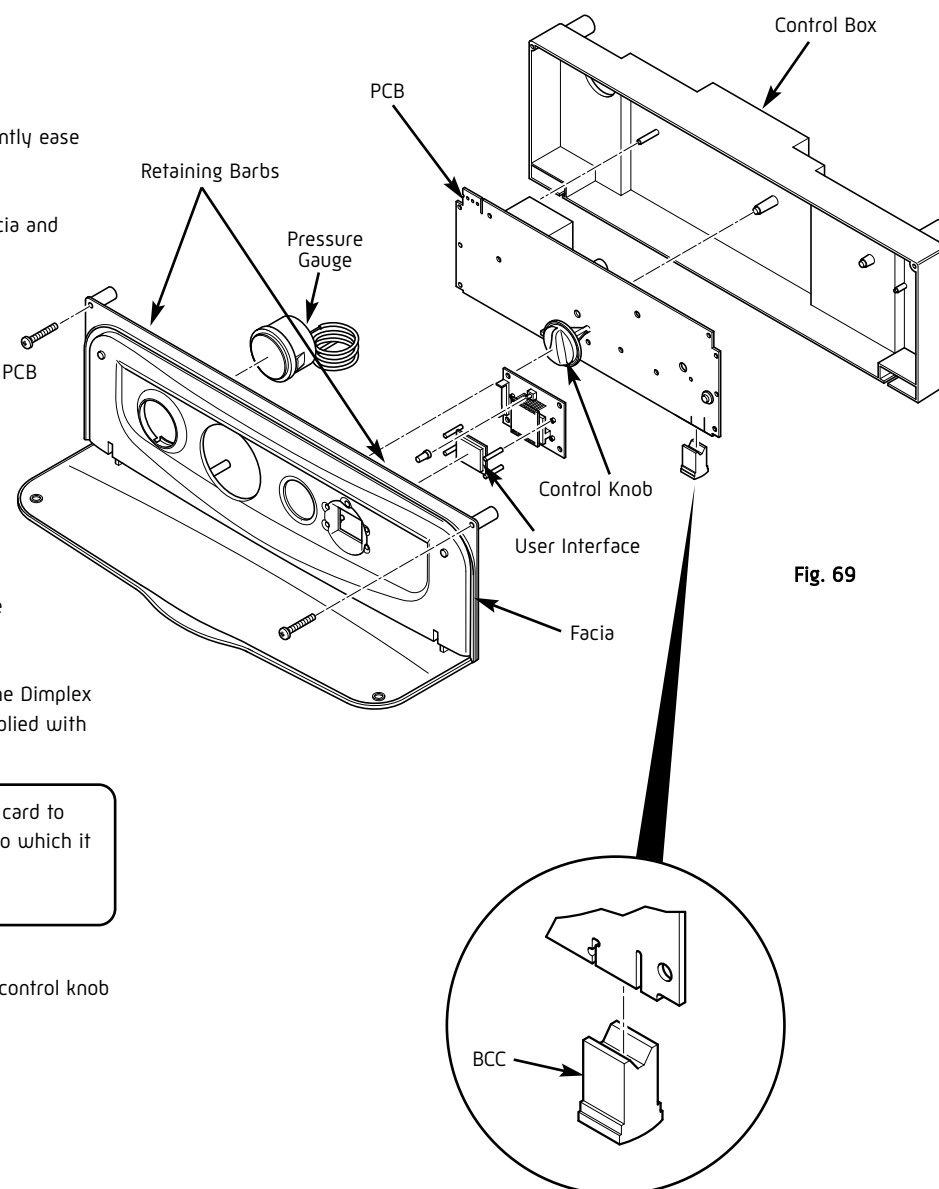

Fig. 69

6.0 SYSTEM DETAILS**6.1 INFORMATION**

1. The Dimplex System Boiler is a 'Water Byelaws Scheme - Approved Product'. Reference to the Water Research Council publications, 'Water fittings and materials directory' and 'Water supply byelaws guide' give full details of byelaws and the IRNs.

6.2 HEATING CIRCUIT

1. The appliance is suitable for fully pumped SEALED SYSTEMS ONLY.

Treatment of Water Circulating Systems

Failure to flush and add inhibitor to the system will invalidate the appliance warranty.

- Central heating water systems will be subject to corrosion unless an appropriate water treatment is applied. This means that the efficiency of the system will deteriorate as corrosion sludge accumulates within the system, risking damage to pump and valves, boiler noise and circulation problems.
- When fitting new systems flux will be evident within the system, which can lead to damage of system components.
- All systems must be thoroughly drained and flushed out. Using, for example Betz-Dearborn Sentinel X300 or X400 or Fernox Superfloc Universal Cleanser. They should be used following the flushing agent manufacturer's instructions.
- System additives - corrosion inhibitors and flushing agents/descalers should comply to BS7593 requirements, e.g. Betz-Dearborn Sentinel X300 and Fernox-Copal which should be used following the inhibitor manufacturer's instructions.
- It is important to check the inhibitor concentration after installation, system modification and at every service in accordance with the manufacturer's instructions. (Test kits are available from inhibitor stockists.)
- For information or advice regarding any of the above contact Technical Enquiries - Tel: 0844 3711121.
- If thermostatic radiator valves are fitted, a radiator must be fitted with two lock shield valves or the system must include a proprietary automatic bypass valve, to enable correct operation of the pump over-run facility.

6.3 SYSTEM CONTROL

1. It is recommended that external controls e.g. room thermostat are fitted to further improve the operating efficiency of the boiler and system.

6.0 SYSTEM DETAILS



6.4 SYSTEM FILLING AND PRESSURISING

1. A filling point connection on the central heating return pipework must be provided for initial filling and pressurising and subsequent topping up of the system.

A filling loop is provided loose with the boiler

2. The filling method adopted must comply with all relevant water supply regulations and use approved equipment.

3. Further details are given in:
for GB: Guidance G24.2 and recommendation R24.2 of the Water Regulations Guide.
for IE: the current edition of I.S. 813 "Domestic Gas Installations".

4. The sealed primary circuits may be filled or topped up using a temporary connection between the circuit and a supply pipe, provided a 'Listed' double check valve or some other no less effective backflow prevention device is permanently connected at the inlet to the circuit and the temporary connection is removed after use.

6.5 EXPANSION VESSEL

1. The appliance expansion vessel is pre-charged to 1 bar. Therefore the minimum cold fill pressure is 2 bar. The vessel is suitable for correct operation for system capacities up to 84 litres. For greater system capacities an additional expansion vessel must be fitted.

For GB refer to BS 7074 Pt 1.

For IE, the current edition of I.S. 813 "Domestic Gas Installations".

Vessel charge and initial system pressure	bar	0.5	0.75	1.0	1.5
Total water content of system using 8 litres capacity expansion vessel supplied with appliance	litres	96	84	73	50
For systems having a larger capacity multiply the total system capacity in litres by this factor to obtain the total minimum expansion vessel capacity required in litres			0.093		

6.6 PRESSURE RELIEF VALVE

1. The pressure relief valve is set at 3 bar, therefore all pipework, fittings, etc. should be suitable for pressures in excess of 3 bar and temperature greater than 100°C.

2. The pressure relief discharge pipe should be not less than 15mm diameter, run continuously downward, and discharge outside the building, preferably over a drain. It should be routed in such a manner that no hazard occurs to occupants or causes damage to wiring or electrical components. The end of the pipe should terminate facing down and towards the wall.

NOTE: Boiling water/steam could discharge from the pipe, therefore it should be terminated away from windows and doors.

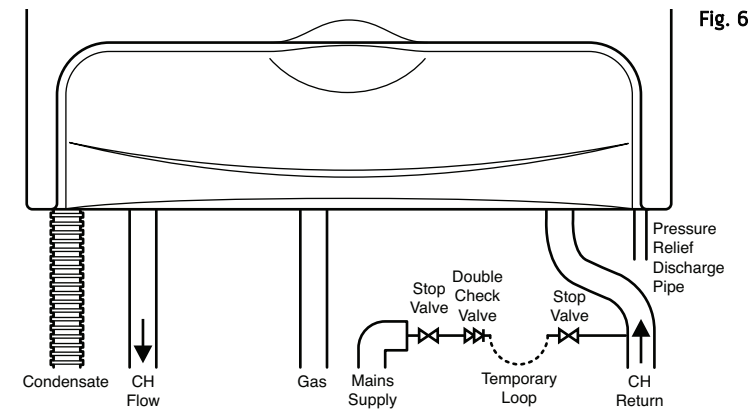

Fig. 6

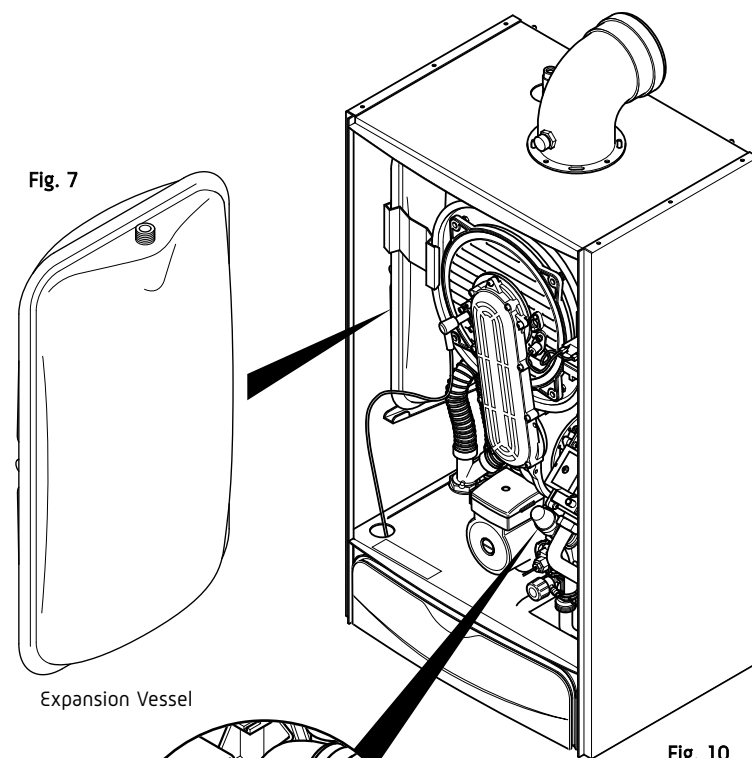

Fig. 7

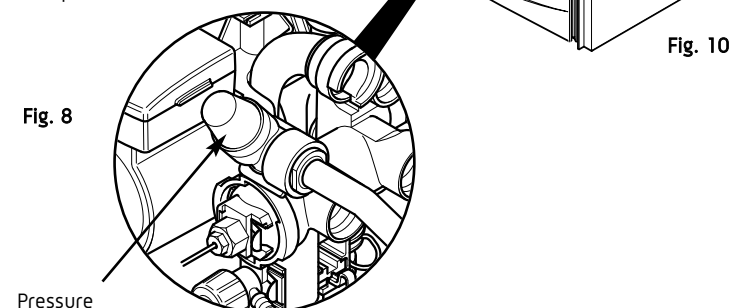

Fig. 8

Pressure Relief Valve

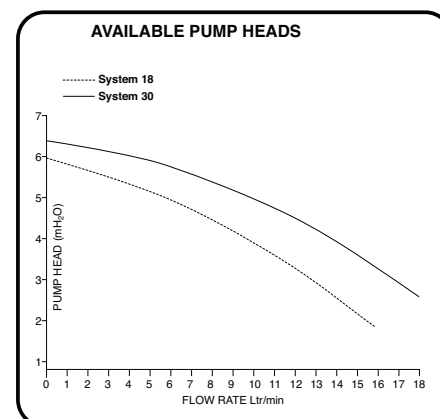

Fig. 9

NOTE: Do not use the pressure relief valve to drain the system, because dirt and debris could prevent the valve seating correctly.

© Dimplex Boilers 2008

13.0 CHANGING COMPONENTS



13.16 EXPANSION VESSEL

1. Drain the primary circuit and undo the nut on the vessel connection pipe.
2. Remove the two screws holding the retaining bracket and remove the bracket (Fig. 67).
3. Carefully slide out the vessel from the boiler.
4. Reassemble in reverse order.

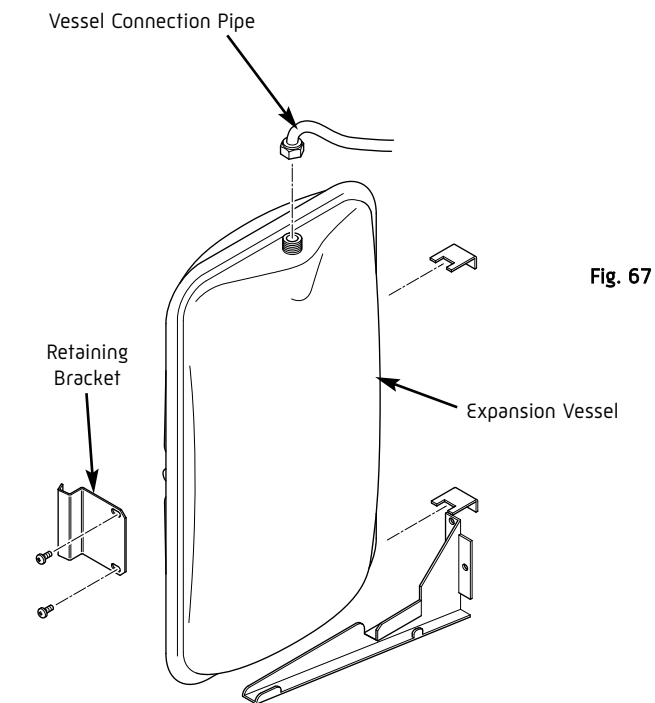

Fig. 67

13.17 MAIN HEAT EXCHANGER

1. Drain the primary circuit.
2. Remove the electrode leads, noting their positions as described in section 13.2.
3. Remove the valve and fan assembly as described in Section 13.3.
4. Examine the gasket and replace if necessary.
5. Undo the four nuts securing the burner door and remove the cover plate from the heat exchanger.
6. Remove the two clips from the flow and return pipes on the bottom of the heat exchanger and slide out the pipes (Fig. 68).
7. Remove the clip holding the manual air vent and remove the pipe from the top of the heat exchanger.
8. Remove the four screws holding the left and right hand retaining brackets and remove the brackets.
9. Remove the four screws securing the flue to the top of the boiler. Lift the flue adaptor out of the flue outlet in the top of the heat exchanger.
10. Carefully slide the heat exchanger out of the boiler.
11. Reassemble in reverse order.

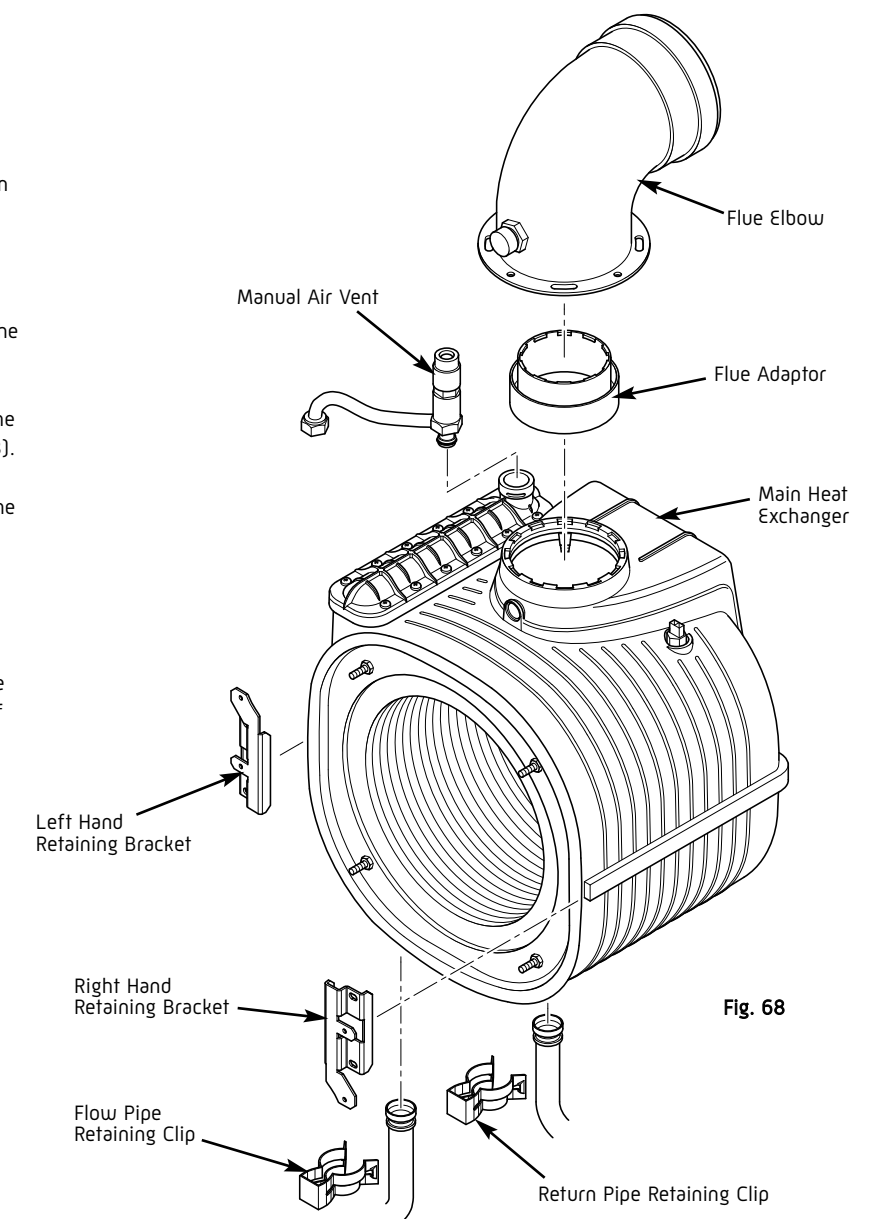

Fig. 68

© Dimplex Boilers 2008

13.0 CHANGING COMPONENTS

dimplex

13.12 AUTOMATIC AIR VENT

1. Drain the primary circuit and rotate the automatic air vent $\frac{1}{4}$ turn and remove from the pump body.
2. Examine the 'O' ring seal, replacing if necessary, and fit it to the new automatic air vent.
3. Reassemble in reverse order.

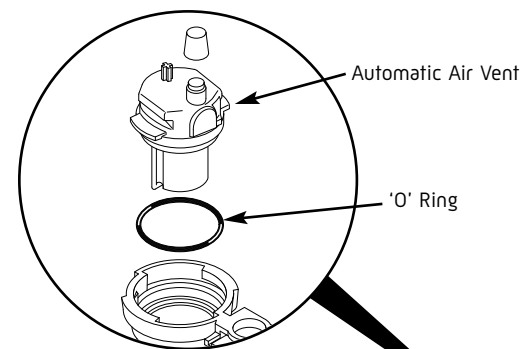
**13.13 PRESSURE GAUGE**

1. Drain the primary circuit and undo the nut on the pressure gauge capillary.
2. Examine the 'O' ring seal, replace if necessary.
3. Unclip the fascia from the control box
4. Lever the barbs securing the gauge to remove the gauge from the control box (Fig. 64).
5. Reassemble in reverse order.

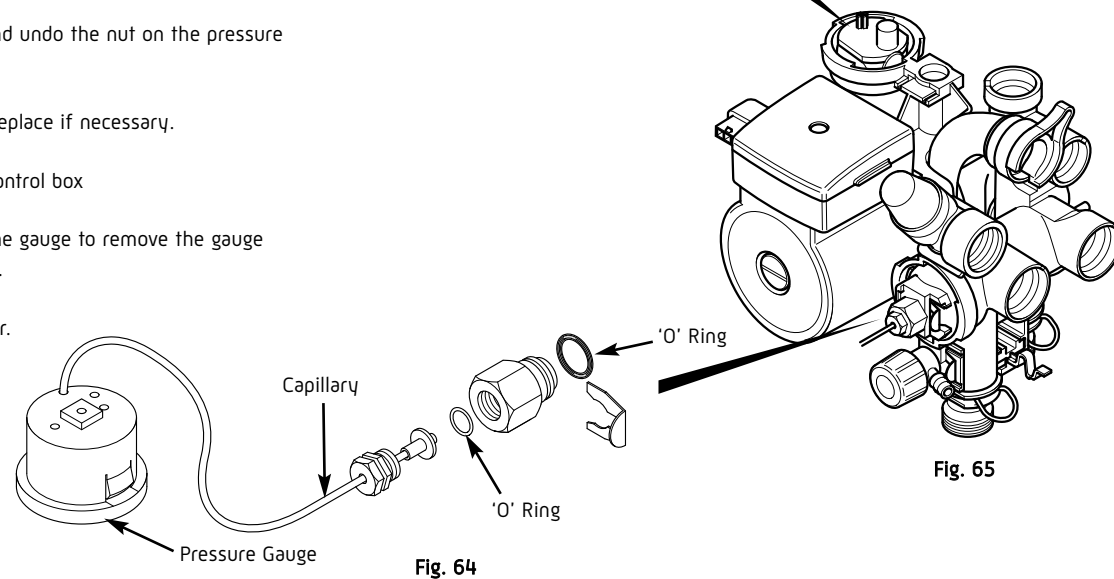

Fig. 65

13.14 PRESSURE RELIEF VALVE

1. Drain the primary circuit.
2. Disconnect the discharge pipe from the valve. Ease off the retaining clip (Fig. 66).
3. Note the orientation of the valve, rotate it and withdraw it from the manifold.
4. Fit the new valve and 'O' ring and set to the previously noted orientation. Reassemble in reverse order.

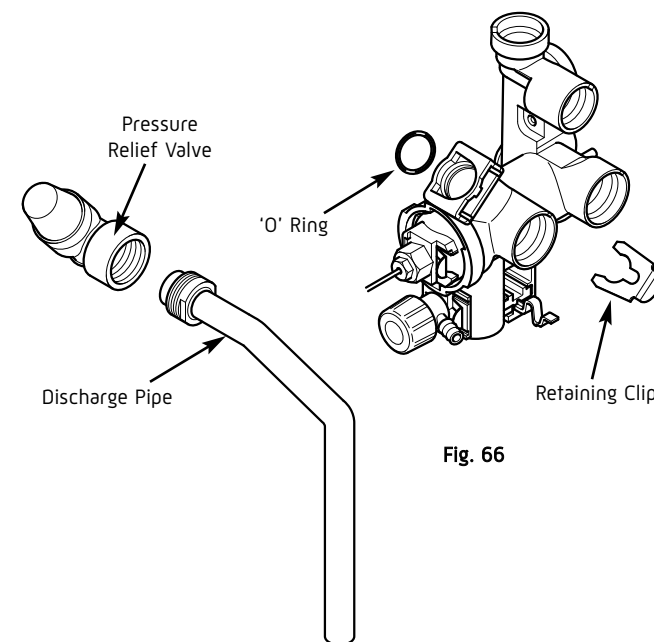

Fig. 66

7.0 SITE REQUIREMENTS

dimplex

7.1 LOCATION

1. The boiler may be fitted to any suitable wall with the flue passing through an outside wall or roof and discharging to atmosphere in a position permitting satisfactory removal of combustion products and providing an adequate air supply. The boiler should be fitted within the building unless otherwise protected by a suitable enclosure i.e. garage or outhouse. (The boiler may be fitted inside an unvented cupboard - see section 7.3).

2. If the boiler is fitted in a room containing a bath or shower reference must be made to the relevant requirements. In GB this is the current I.E.E. Wiring Regulations and Building Regulations.

In IE reference should be made to the current edition of I.S. 813 "Domestic Gas Installations" and current ETCI rules. (Fig. 11 shows zone dimensions for a bathtub. For other examples refer to Section 601 of the current I.E.E. Wiring Regulations) reference must be made to the relevant requirements.

The boiler is IPX4 rated and can be fitted in Zone 2 (Fig. 11).

3. If the boiler is to be fitted into a building of timber frame construction then reference must be made to the current edition of Institute of Gas Engineers Publication IGE/UP/7 (Gas Installations in Timber Framed Housing).

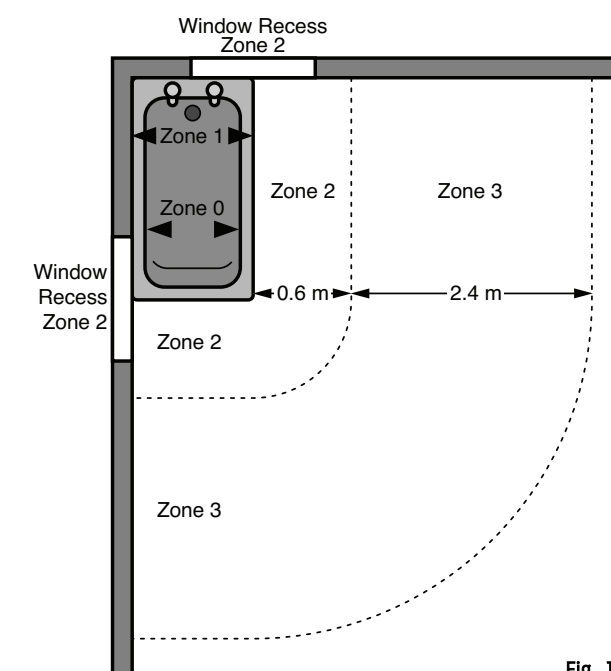

Fig. 11

7.2 CLEARANCES

1. A flat vertical area is required for the installation of the boiler.

2. These dimensions include the necessary clearance around the boiler for case removal, spanner access and air movement. Additional clearances may be required for the passage of pipes around local obstructions such as joists running parallel to the front face of the boiler.

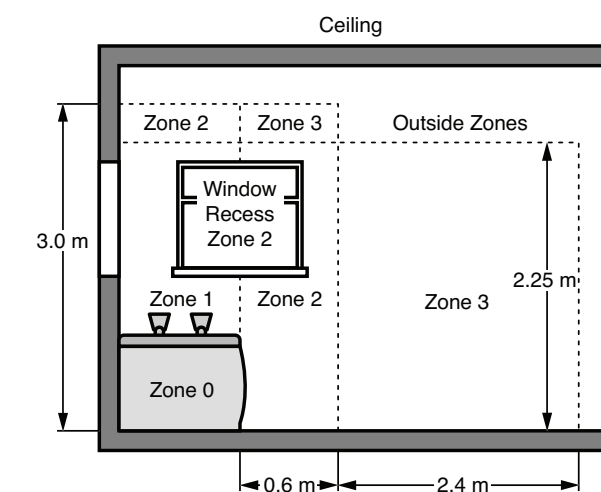
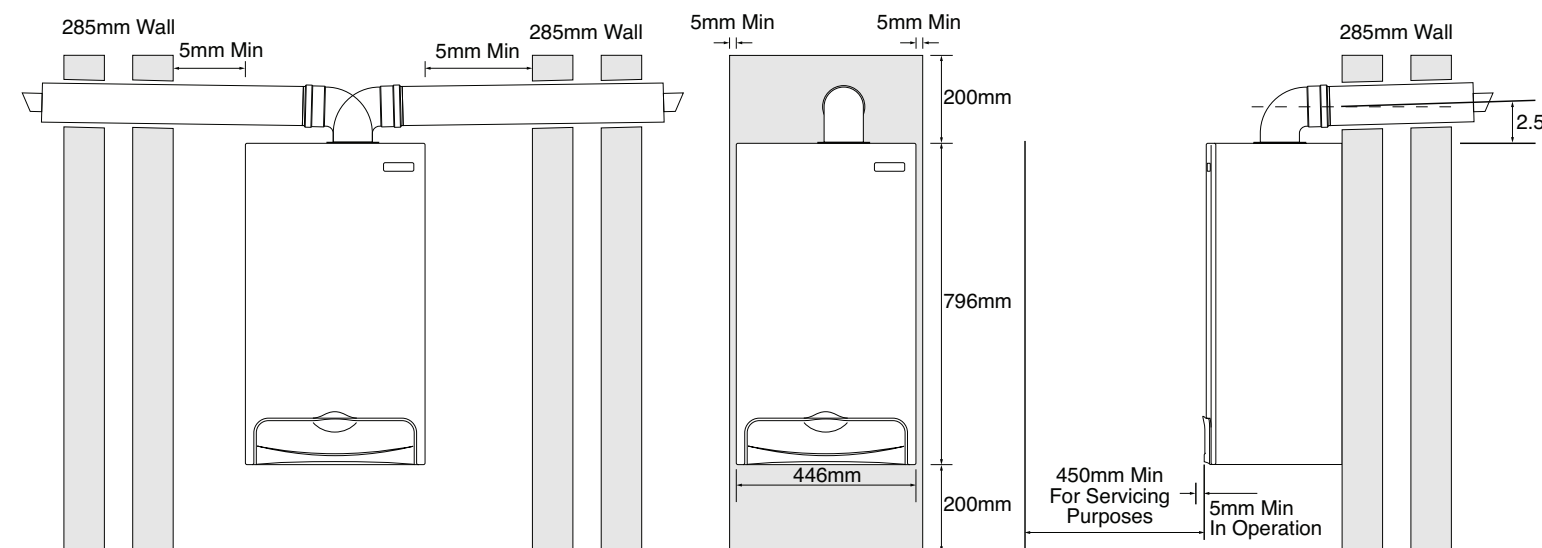

Fig. 12



7.0 SITE REQUIREMENTS**7.3 VENTILATION OF COMPARTMENTS**

1. Where the appliance is installed in a cupboard or compartment, no air vents are required.

Where an open flued system is used - Flue kit E (B23 classification) then an air vent communicating directly with outside air must be provided in the same room or internal space of the flue duct air inlet. Minimum free area:

System 18 = 88cm²
System 30 = 159cm²

In addition if an open flued system is used - Flue kit (B23 classification) and the boiler is fitted in a compartment, then high and low level ventilation is required.
BS 5440-2:2000 gives guidance on compartmental ventilation.

2. When the boiler is installed in a cupboard or compartment and either flue kit A, B, C, D or F (Classification C13, C33, C53) is used, then no compartmental ventilation is required.

7.4 GAS SUPPLY

1. The gas installation should be in accordance with the relevant standards. In GB this is BS 6891. In IE this is the current edition of I.S. 813 "Domestic Gas Installations".

2. The connection to the appliance is a 22mm copper tail located at the rear of the gas service cock (Fig. 13).

3. Ensure that the pipework from the meter to the appliance is of adequate size, and the demands of any other gas appliance in the property are taken into consideration. Do not use pipes of a smaller diameter than the boiler gas connection (22mm).

4. For boilers connected to use LPG (propane), the inlet pressure must be 37mbar.

NOTE: The completed installation should always be tested for gas tightness

7.5 ELECTRICAL SUPPLY

1. External wiring must be correctly earthed, polarised and in accordance with relevant regulations/rules. In GB this is the current I.E.E. Wiring Regulations. In IE reference should be made to the current edition of the ETGI rules.

2. The mains supply is 230V - 50Hz fused at 3A

NOTE: The mains supply connection must allow complete electrical isolation of the appliance and system controls only.
Connection may be via a fused double-pole isolator with a contact separation of at least 3mm in all poles and servicing the boiler and system controls only.
Any additional mains cable should comply fully with the current I.E.E. wiring regulations.

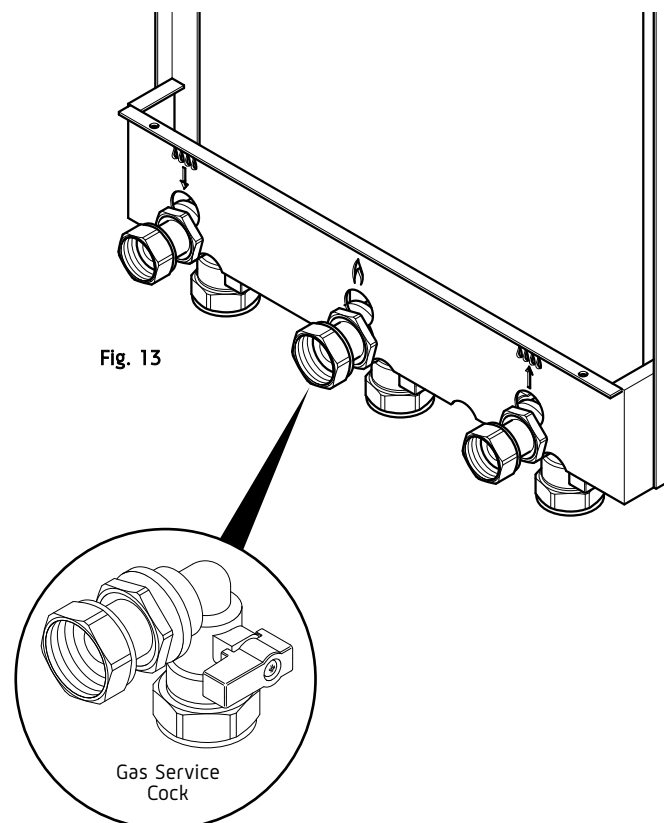

Fig. 13

Gas Service
Cock**13.0 CHANGING COMPONENTS****13.10 PUMP - HEAD ONLY**

1. Drain the primary circuit and disconnect the wiring connector from the pump head.

2. Remove the four socket head screws securing the pump head to the body and draw the head away (Fig. 62).

3. A replacement Grundfos 15-60 head can now be fitted (Fig. 62)(Part No: 500672).

4. Reassemble in reverse order.

5. Replace the wiring connector into the socket on the pump head.

13.11 HYDROBLOCK

1. Drain the primary circuit.

2. Remove the stainless clip at the base of the hydro-block and disconnect the pipe (Fig. 63).

3. Un-lock the locking clip on the return port.

4. Disconnect the discharge pipe from the pressure relief valve.

5. Remove the two securing screws from below the boiler.

6. Carefully remove the hydro-block and change the relevant components.

7. Reassemble in reverse order taking care to replace all the clips correctly. Ensure the locking clip is in the 'Locked' position as shown opposite.

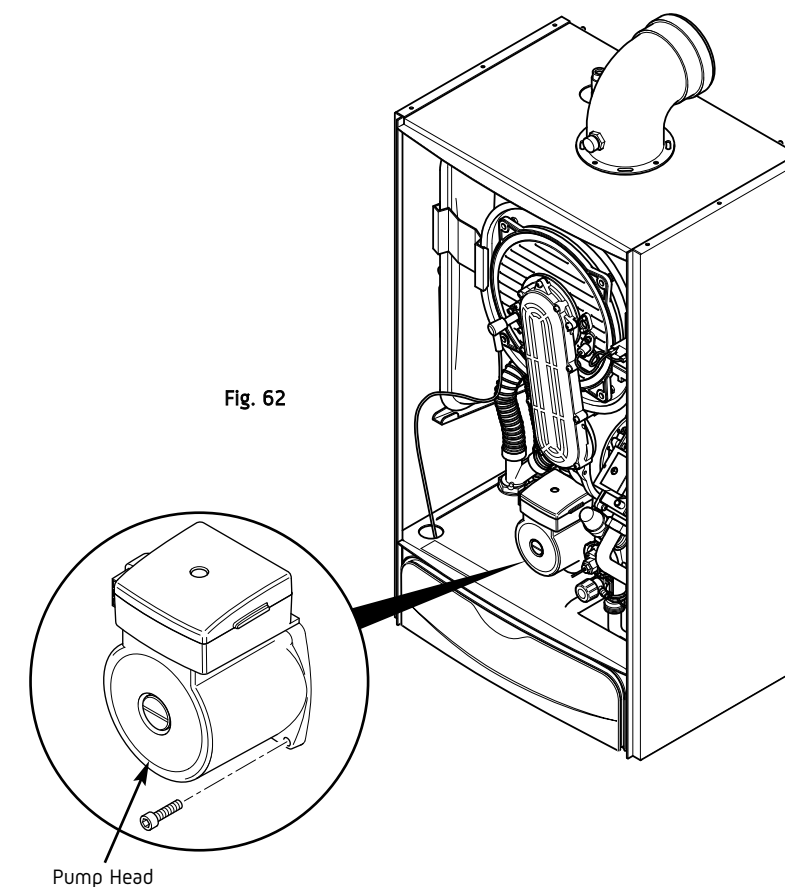

Fig. 62

Pump Head

Un-Locked
(viewed from pipe end)Locked
(viewed from pipe end)

Fig. 63

Front
Stainless ClipRear
Stainless Clip

X 2

13.0 CHANGING COMPONENTS

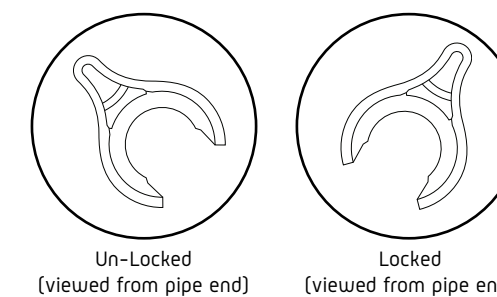
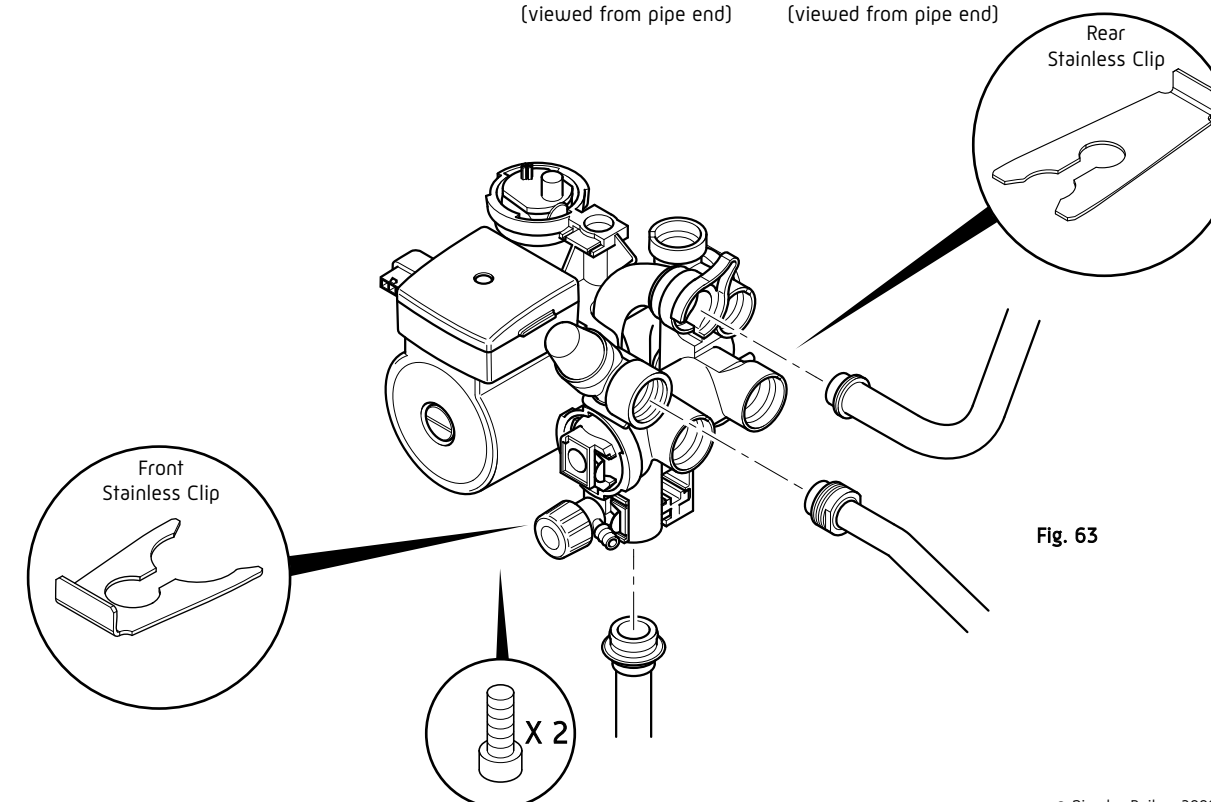

13.6 FLUE/HEAT TEMPERATURE THERMOSTAT

1. Disconnect the electrical plug.
2. Turn the sensor 90° anticlockwise to remove - it is a bayonet connection (Fig. 60).
3. Reassemble in reverse order.

13.7 THERMAL FUSE

1. The thermal fuse is non-changeable. If the fuse fails contact Dimplex Technical Department.

13.8 CENTRAL HEATING FLOW TEMPERATURE THERMISTOR

1. Disconnect the electrical plug.
2. Ease the sensor clip away from the pipe and remove (Fig. 61).
3. Reassemble in reverse order.

13.9 CENTRAL HEATING RETURN TEMPERATURE THERMISTOR

1. Disconnect the electrical plug.
2. Ease the sensor clip away from the pipe and remove (Fig. 61).
3. Reassemble in reverse order.

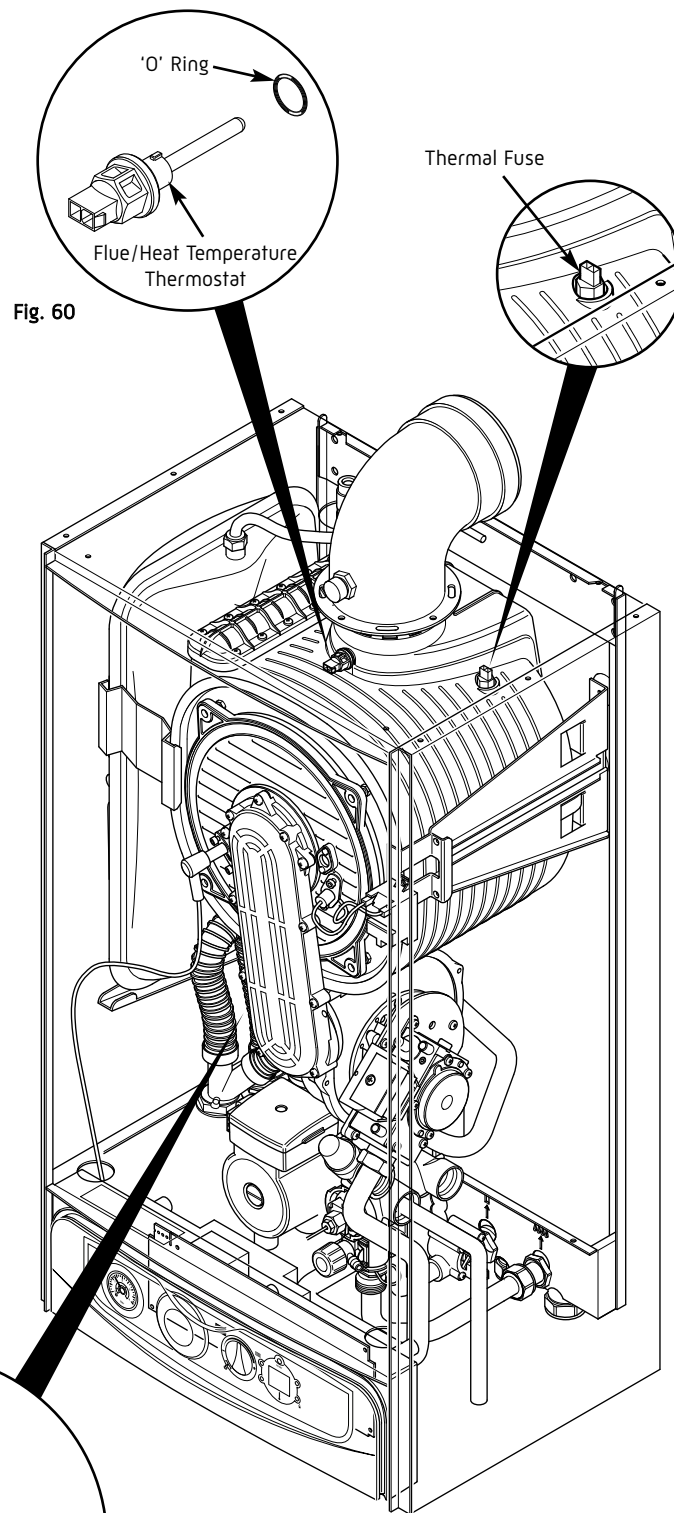

Fig. 60

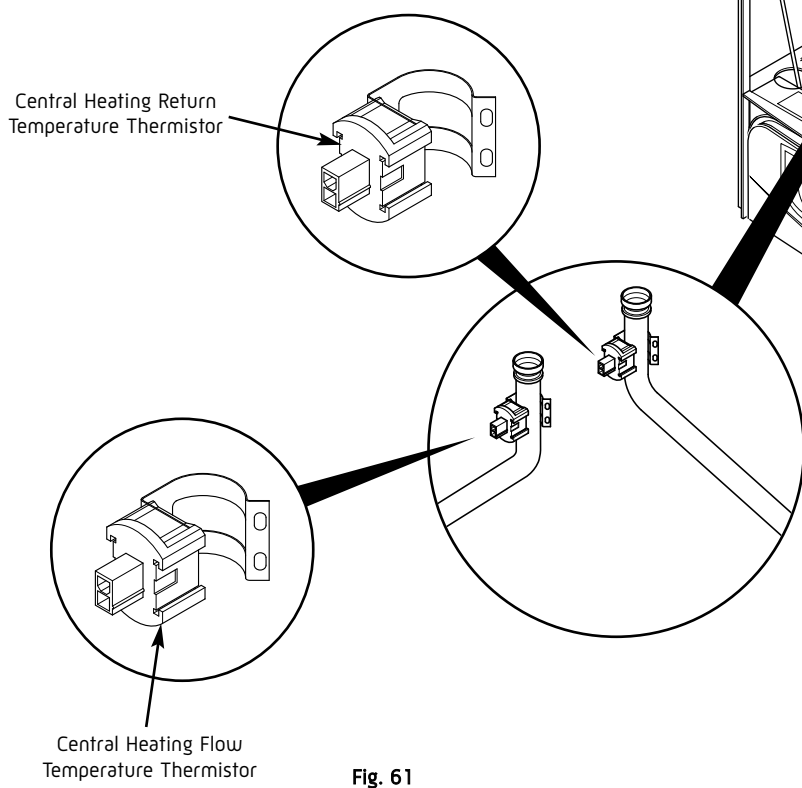

Fig. 61

7.0 SITE REQUIREMENTS



7.6 CONDENSATE DRAIN

NOTE: The appliance is fitted with a trap the depth of which is $\geq 75\text{mm}$, therefore no other traps are required in the condensate run.

The condensation discharge pipe must not rise at any point along its length. There **MUST** be a fall of AT LEAST 2.5° (50mm per metre) along the entire run.

1. The condensate outlet will accept 21.5mm (3/4 in) plastic overflow pipe which should discharge internally into the household drainage system, downstream of all other traps. If this is not possible, discharge into an outside drain is acceptable.

2. Ensure the discharge of condensate complies with any national or local regulations in force.

BS 6798:2000 & Part H1 of the Building Regulations give further guidance.

3. Metal pipework is NOT suitable for use in condensate discharge systems.

4. The pipe should be a minimum of 21.5mm diameter and must be supported properly.

5. It is advisable to keep the condensate pipe internal.

6. External runs greater than 3 metres or runs in cold areas should use 32mm waste pipe.

7. If the boiler is fitted in an unheated location the entire condensate discharge pipe should be treated as an external run.

8. In all cases discharge pipe must be installed to aid disposal of the condensate.

9. When discharging condensate into a soil stack or waste pipe the effects of existing plumbing must be considered. If soil pipes or waste pipes are subjected to internal pressure fluctuations when WC's are flushed or sinks emptied then back-pressure may force water out of the boiler trap and cause appliance lockout.

Examples are shown of the following methods of terminations (see figs. 14, 15 & 16):

- i) to an internal soil & vent pipe
- ii) via an internal discharge branch (e.g. sink waste)
- iii) to a drain or gully
- iv) to a purpose made soakaway

10. In exceptional circumstances, such as when a boiler is installed in a basement without drainage, it may be necessary to install a condensate pump to carry condensate up to ground/drain level. Such products are available from most plumbing merchants. For help with selecting a condensate pump contact Dimplex Boilers - Tel: 0844 3711121.

WARNING: There must be no air breaks in the condensate pipework or drainage system (see Fig. 17).

Termination to an internal soil and vent pipe

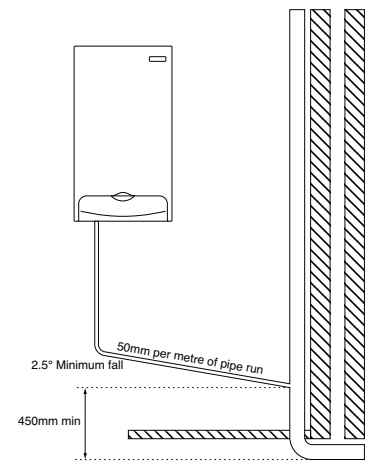

Fig. 14

External termination via internal discharge branch e.g. sink waste - downstream

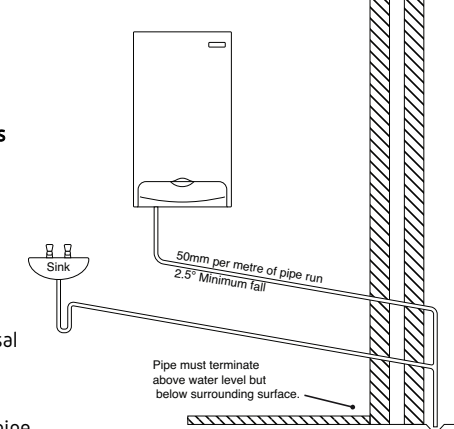

Fig. 15

Termination to a purpose made soak-away

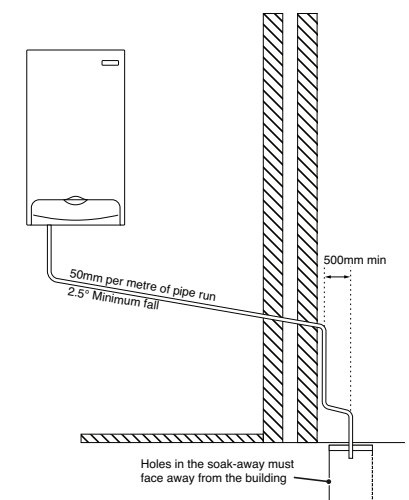

Fig. 16

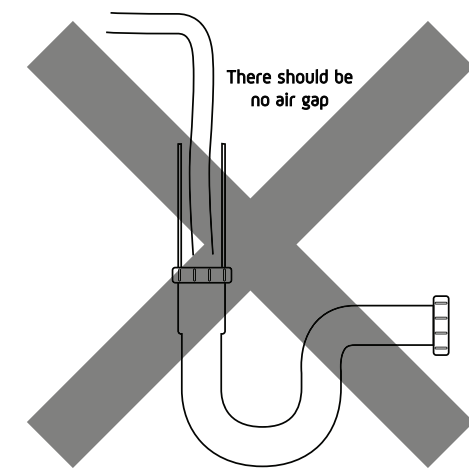

Fig. 17

7.0 SITE REQUIREMENTS



7.7 FLUE

1. This high efficiency boiler will discharge a plume of water vapour from the flue. This should be considered when siting the flue terminal.
2. The following guidelines indicate the general requirements for siting balanced flue terminals. For GB recommendations are given in BS 5440 Pt 1. For IE recommendations are given in the current edition of I.S. 813 "Domestic Gas Installations".
3. If the terminal discharges onto a pathway or passageway, check that combustion products will not cause a nuisance and that the terminal will not obstruct the passageway.
4. If a terminal is less than 2 metres above a balcony, above ground or above a flat roof to which people have access, then a suitable terminal guard must be provided - Part No: 951507.

IMPORTANT:

- Only **ONE** of the 25mm clearances (Positions 'O' to 'S' in the chart below) is allowable per installation.
- Under car ports we recommend the use of the plume displacement kit.
- The terminal position must ensure the safe and nuisance - free dispersal of combustion products.

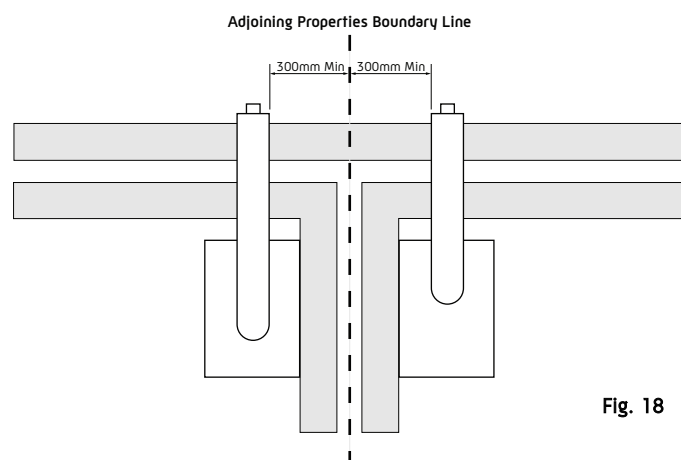
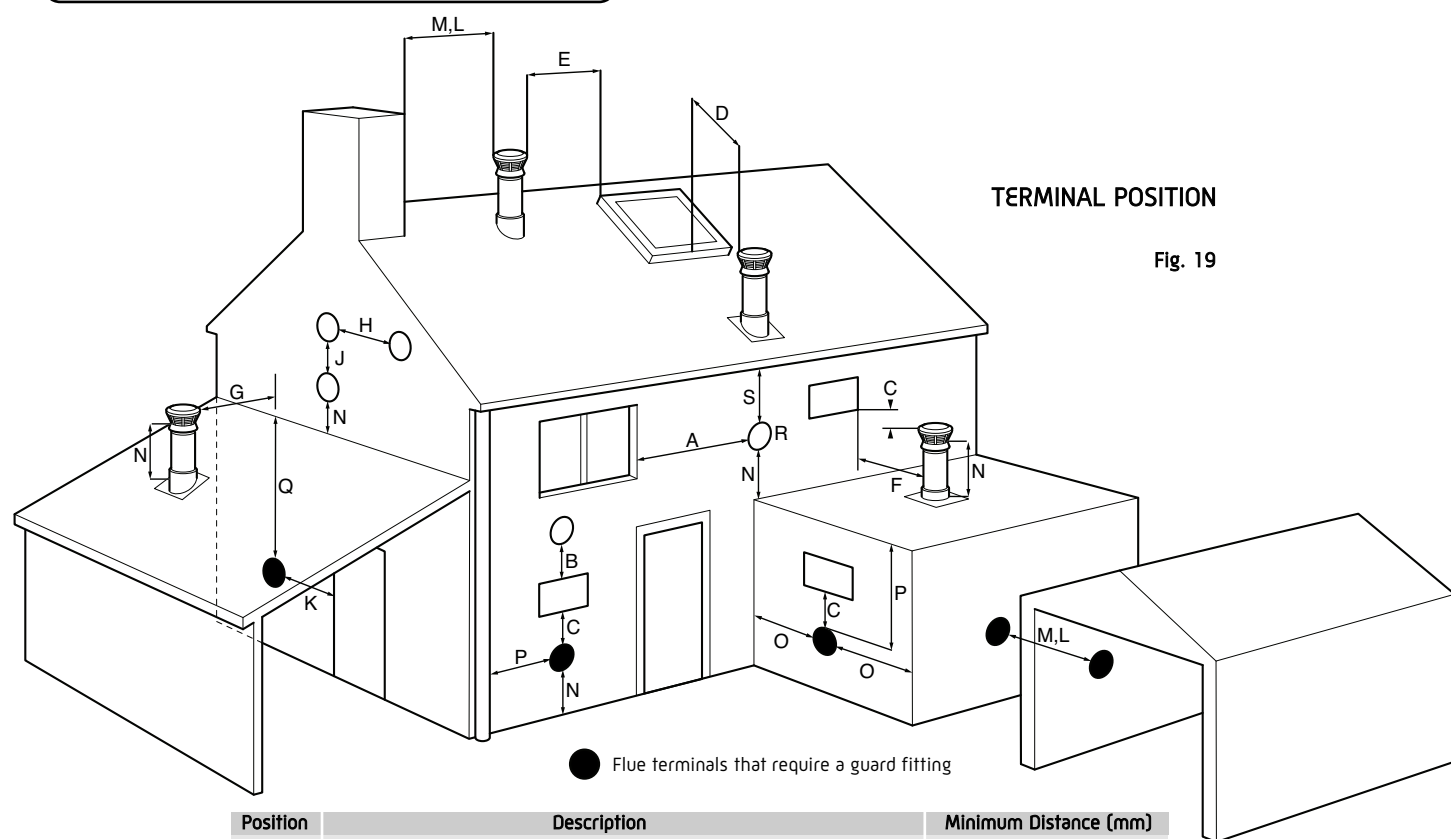

Fig. 18

NOTE: The minimum distance from a flue terminal to a boundary line is 300mm.

If fitting a plume diverter kit, the air inlet should be a minimum of 100mm from any opening windows or doors.



Position	Description	Minimum Distance (mm)
A	Horizontally to an opening, air brick, opening window - see note A	300
B	Above an opening, air brick, opening window etc. - see note A	300
C	Below an opening, air brick, opening window etc. - see note A	300
D	Below windows or openings on pitched roofs	2000
E	Adjacent to windows or openings on pitched and flat roofs	600
F	From an adjacent opening window (vertical only)	1000
G	From an adjacent wall to flue (vertical only)	300
H	Horizontally from a terminal on the same wall	300
J	Vertically from a terminal on the same wall	1500
K	From an opening in a carport (e.g. door, window) into the dwelling	1200
L	From a terminal facing a terminal (horizontal flue)	1200
	From a terminal facing a terminal (vertical flue)	600
M	From a surface or boundary line facing a terminal	600
N	Above ground, roof or balcony level	300
O	From an internal or external corner	25
P	From a vertical drain pipe or soil pipe	25
Q	Below balconies or car port roof	25
R	Below eaves	25
S	Below gutters, soil pipes or drain pipes	25

NOTE: Fitting of the deflector elbow is recommended when installing boiler to minimum clearance of 25mm as detailed in positions O & P.

NOTE A: A terminal should be no closer than 150mm to an opening in the brickwork intended to accommodate a fitting such as a window frame.

13.0 CHANGING COMPONENTS



13.4 BURNER

1. Remove the valve and fan assembly as described in Section 13.3.
2. Examine the gasket and replace if necessary.
3. Undo the four nuts securing the burner door and remove from the heat exchanger.
4. Slowly withdraw the burner from the burner plate taking care not to damage the insulation (Fig. 58).
5. Reassemble in reverse order.

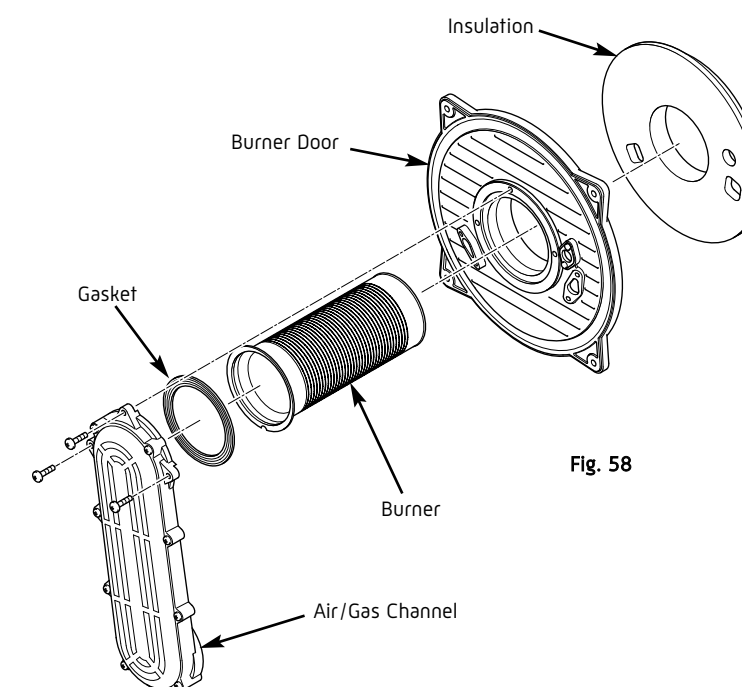

Fig. 58

13.5 INSULATION

1. Remove the electrode leads, noting their positions. Remove the electrodes as described in section 13.2.
2. Remove the valve and fan assembly as described in Section 13.3.
3. Examine the gasket and replace if necessary.
4. Undo the four nuts securing the burner door and remove from the heat exchanger.
5. Slowly withdraw the burner from the burner door.
6. Replace the insulation if necessary.
7. Check the burner door seals.
8. The rear insulation is retained by a screw and large washer, remove these and draw the insulation out of the heat exchanger (Fig. 59).
9. Reassemble in reverse order.

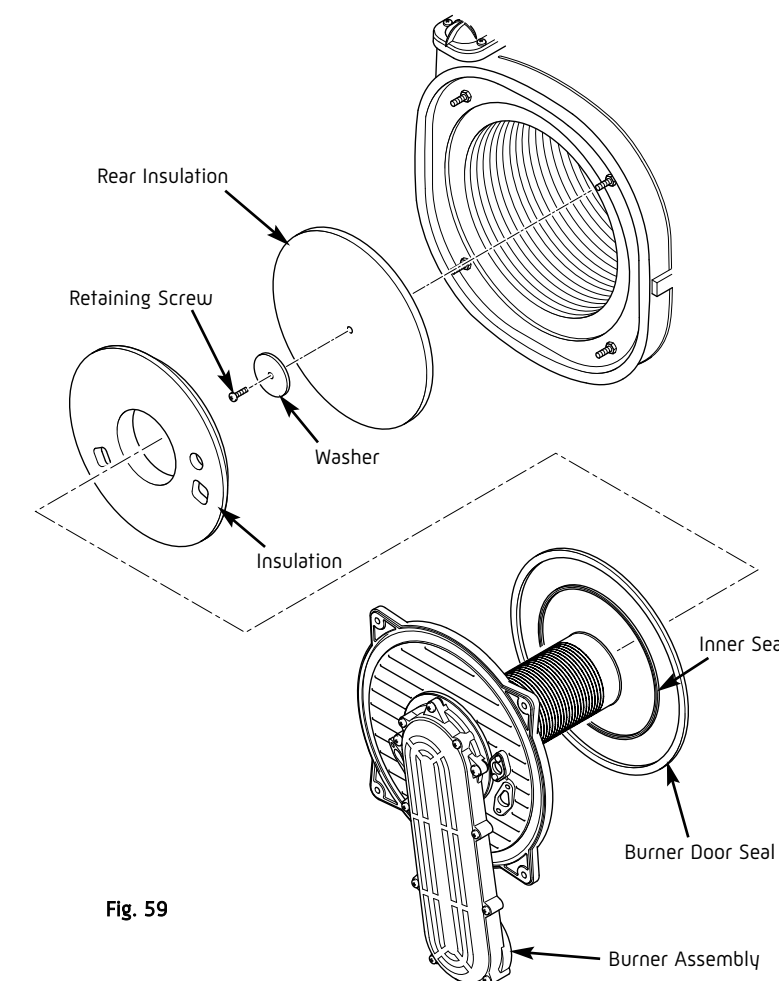

Fig. 59

13.0 CHANGING COMPONENTS



13.3 GAS VALVE AND FAN

1. Disconnect the two leads to the fan and one lead to the gas valve.
2. Undo the nut on the gas inlet pipe to the valve and retain the sealing washer.
3. Remove the three securing screws holding the air/gas Channel to the burner door plate and remove the valve and fan assembly (Fig. 57).
4. Remove the three screws holding the valve and swirl plate to the fan adaptor plate.

NOTE: Mark on the adaptor plate which holes are being used by the screws. Using the wrong holes on re-assembly will cause mis-alignment of the gas valve.

Fan Only

6. Remove the three screws holding the fan adaptor to the fan.
7. Remove the four screws securing the fan to the air/gas channel. Reassemble in reverse order ensuring all seals are in place.

NOTE: The gas valve throttle should be adjusted in accordance with the instructions supplied in the spares kit. See Section 10.

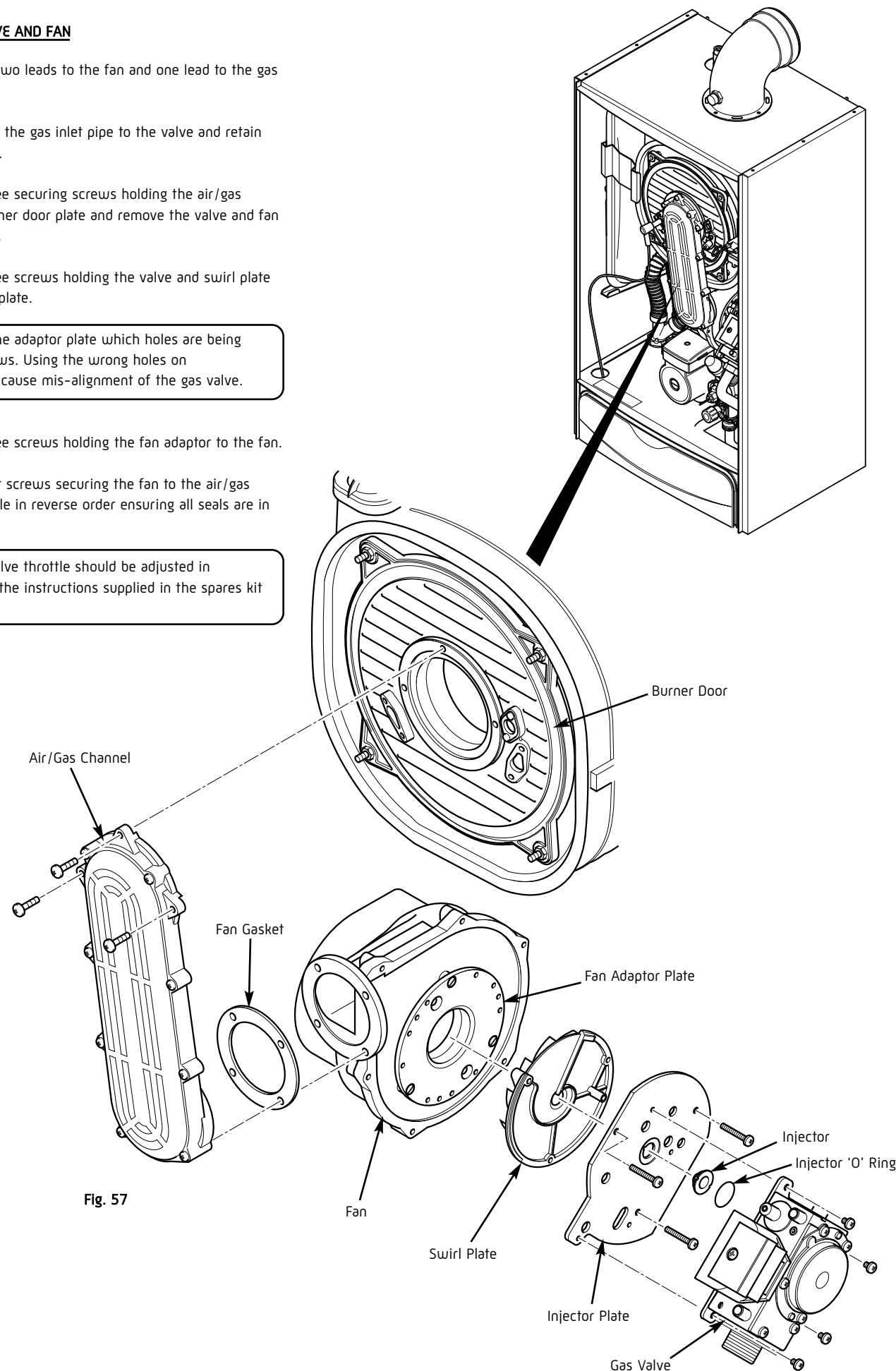

Fig. 57

8.0 FLUE OPTIONS



8.1 CONCENTRIC AIR/FLUE DUCT SPECIFICATIONS

The Dimplex System 18 & Dimplex System 30 boilers can be installed to a number of different concentric flue systems. The different flue applications as shown in Fig. 20 are available as kits comprising the connecting parts to the appliance and end terminal. Flue extension ducts and extension elbows are available as accessories.

Note: Dimplex System 18 only, with maximum concentric flue length of 10m, the heat input will be reduced by 7.6%

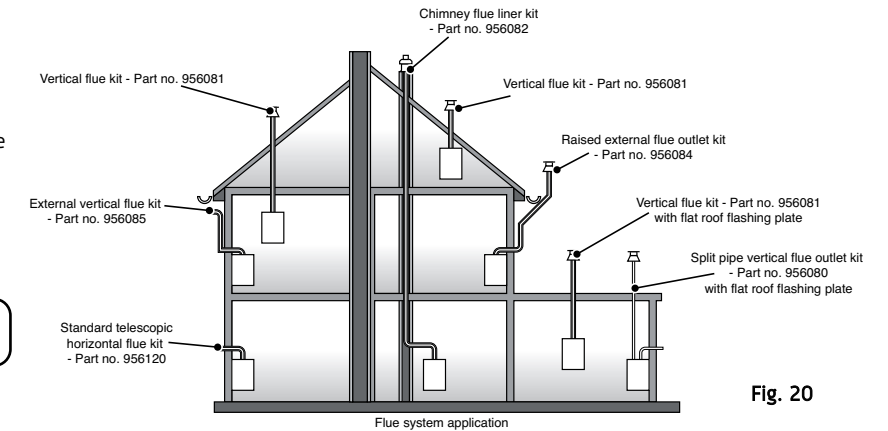

Fig. 20

8.2 Kit A + Telescopic Horizontal Wall Terminal (C13) - Part No. 956120

Traditional concentric flue system, Fig. 21, with a maximum length of 10000mm. The flanged flue elbow is designed with a 3° slope towards the appliance so that the condensate can easily drain off. It has to be considered that for every metre horizontal flue length the terminal exit centreline is approx. 45 mm higher than the elbow's centreline. The standard telescopic terminal is 615mm max length and 430mm min length, but can be cut to a minimum flue length of 250mm, which is suitable for single, 100mm (4"), brick walls.

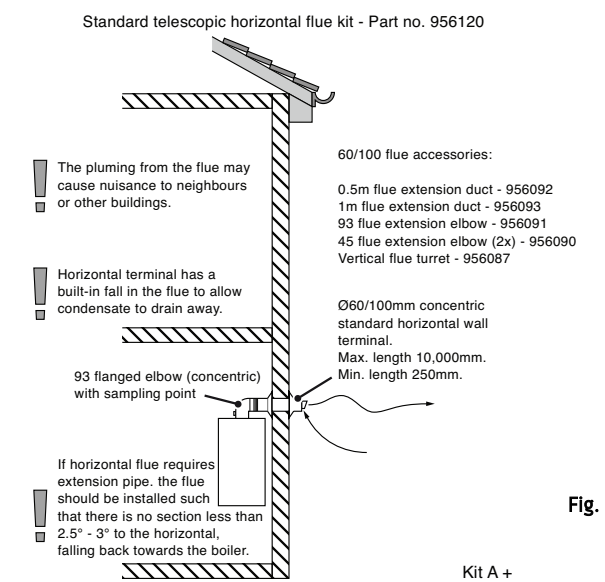

Fig. 21

Kit A +

8.3 Kit B Vertical Concentric Flue Terminal (C33) - HBL Part 956081

Standard concentric (100/60) vertical flue application, Fig. 22, through roof attics with a maximum length of 12000mm. The kit comprises of the roof terminal, flashing kit, vertical adaptor with sampling point and bracket. The maximum length is measured from the top of the appliance casing to the underside of the air cowl. For installation details refer to the flue kit instructions.

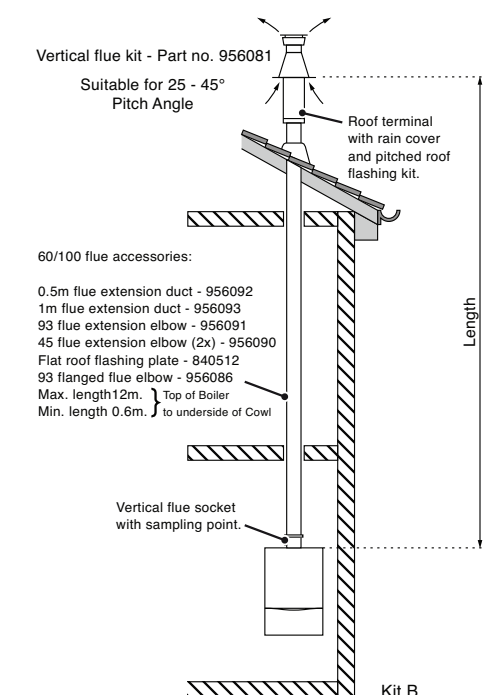

Fig. 22

Kit B

8.0 FLUE OPTIONS

8.4 Offset Vertical Flue Terminal
(C33) - HBL Part 956081

'a' measured from boiler flue outlet centre line to the centre line of the extension elbow.
'b' measured from the top of the boiler to the underside of the air cowl.
Maximum allowable length of a + b = 8900mm

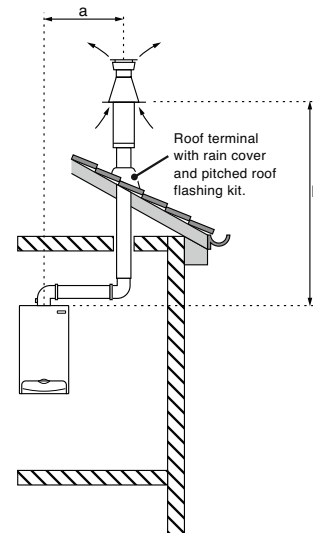

Fig. 23

8.5 Kit C Horizontal Anti-Plume Flue Kit
(C13) - Part No. 956084

If the standard horizontal terminal is likely to cause nuisance to a neighbour or buildings, because of excess plumbing, then this particular flue kit raises the flue gas outlet point to a higher elevation with the minimum amount of changes. The flue gas duct is teed-off from the concentric part and covered by an 80mm outer tube to protect the flue duct from freezing. The air in-take remains at the lower level (see Fig. 24).
If choosing this option then the external flue duct length should be taken into account when calculating equivalent flue length.

For installation details refer to the flue kit instructions.
Dimensions from vertical terminals to opening windows should be in line with Fig. 19.

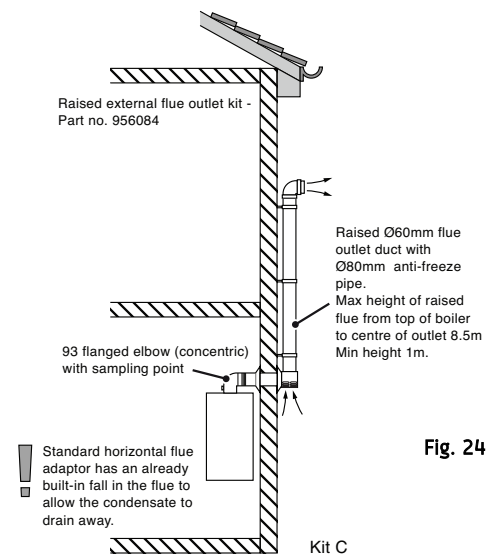

Fig. 24

8.6 Plume Diverter Terminal Kit
Part No. 956103

(For use with Standard horizontal telescopic flue kit - Part no. 956120 - only).

This kit is provided to assist in fitting a condensing boiler with reduced clearances when fitted in good practice according to the Guide to Condensing Boiler Installation published by DEFRA/HMSO.

This kit allows the boiler flue outlet to be directed to the left or to the right only.

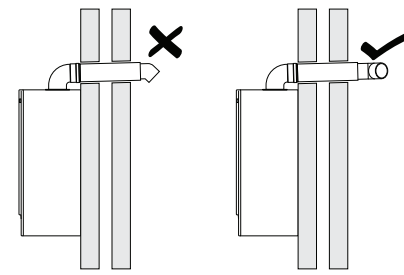

Fig. 25

8.7 Kit D External Vertical Flue
(C33) - Part no. 956085

Suitable for installations if the appliance cannot be repositioned and where other horizontal flue options may cause some nuisance to neighbours or buildings. The flue kit contains some additional 45° elbows and extension ducts as well as a special wall bracket to pass the guttering (see Fig. 26). The concentric flue will be routed vertically alongside the outside wall to above the roofline. Special seals are required to prevent rainwater penetrating the pipe joints.

For installation details refer to the flue kit instructions.

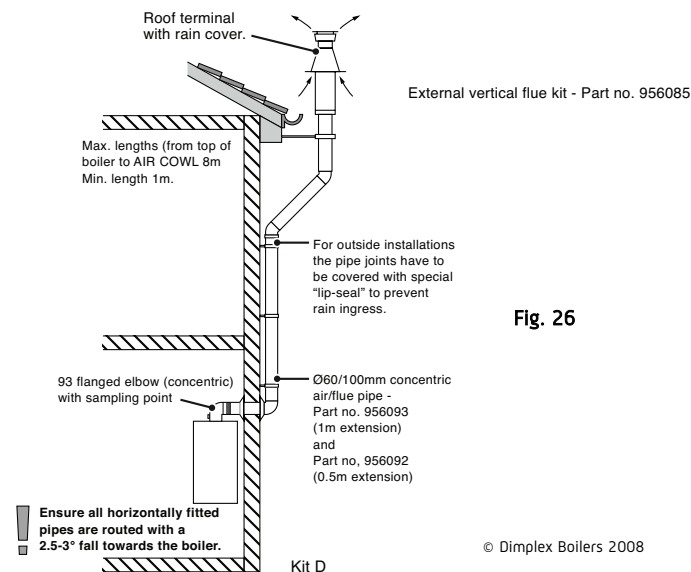

Fig. 26

© Dimplex Boilers 2008

13.0 CHANGING COMPONENTS



IMPORTANT: When changing components ensure that both the gas and electrical supplies to the boiler are isolated before any work is started.

See Section 12 : "Annual Servicing" for removal of case, panel, door etc.

13.1 IGNITER

1. Disconnect the two feed wires, earth wire and electrode lead noting their positions (Fig. 53).
2. Undo the two screws securing the igniter to its bracket and remove the igniter. Reassemble in reverse order.

13.2 SPARK AND SENSING ELECTRODES

1. Disconnect the electrode leads, noting their positions (Fig. 56).
2. Using a 3mm Hex key, remove the retaining screws securing each of the electrodes to the burner door and remove the electrodes.
3. Check the condition of the sealing gaskets and replace if necessary. Reassemble in reverse order and then check that the electrode gaps are as shown in Fig. 54 & 55.

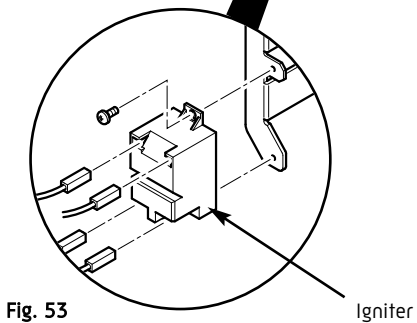
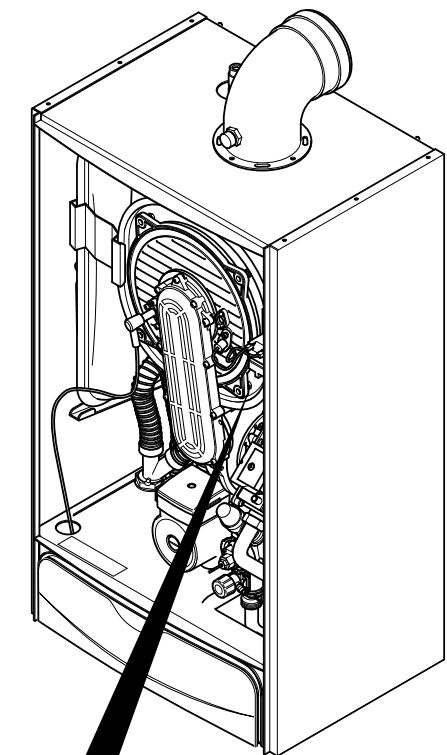

Fig. 53

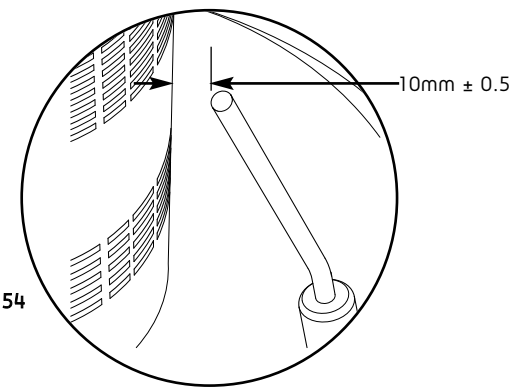

Fig. 54

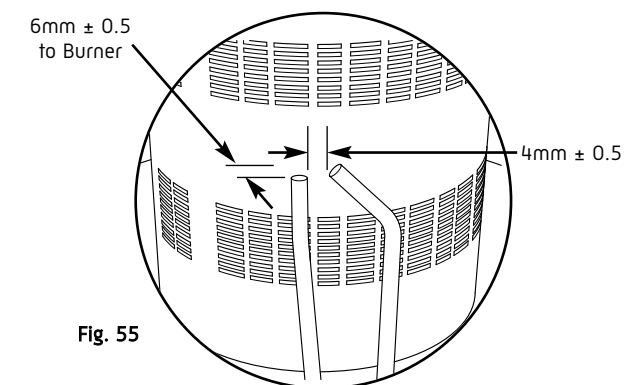

Fig. 55

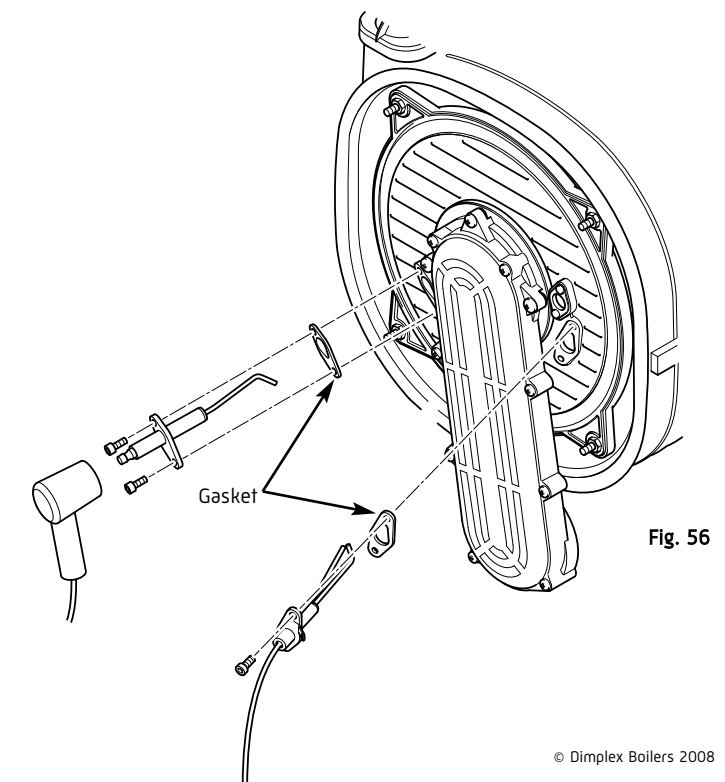

Fig. 56

© Dimplex Boilers 2008

31

12.0 SERVICING AND MAINTENANCE



12.1 ANNUAL SERVICING

8. Remove the two screws securing the front panel to the underside of the boiler. Lift the panel upwards off its retaining studs on top of the appliance.
9. Disconnect the two leads to the fan and one lead to the gas valve.
10. Undo the nut on the gas inlet pipe to the valve and retain the sealing washer.
11. Remove the four nuts holding the burner door plate and remove the valve and fan assembly (Fig. 51).
12. Clean any debris from the heat exchanger using a soft brush and check that the gaps between the tubes are clear.
13. Inspect the burner, electrode positions and insulation, cleaning or replacing if necessary.
14. Check the condition of the burner door seals, replacing if necessary.
15. Reassemble in reverse order.
16. Complete the relevant Service Interval Record section of the Benchmark Commissioning Checklist at the rear of this publication and then hand it back to the user.

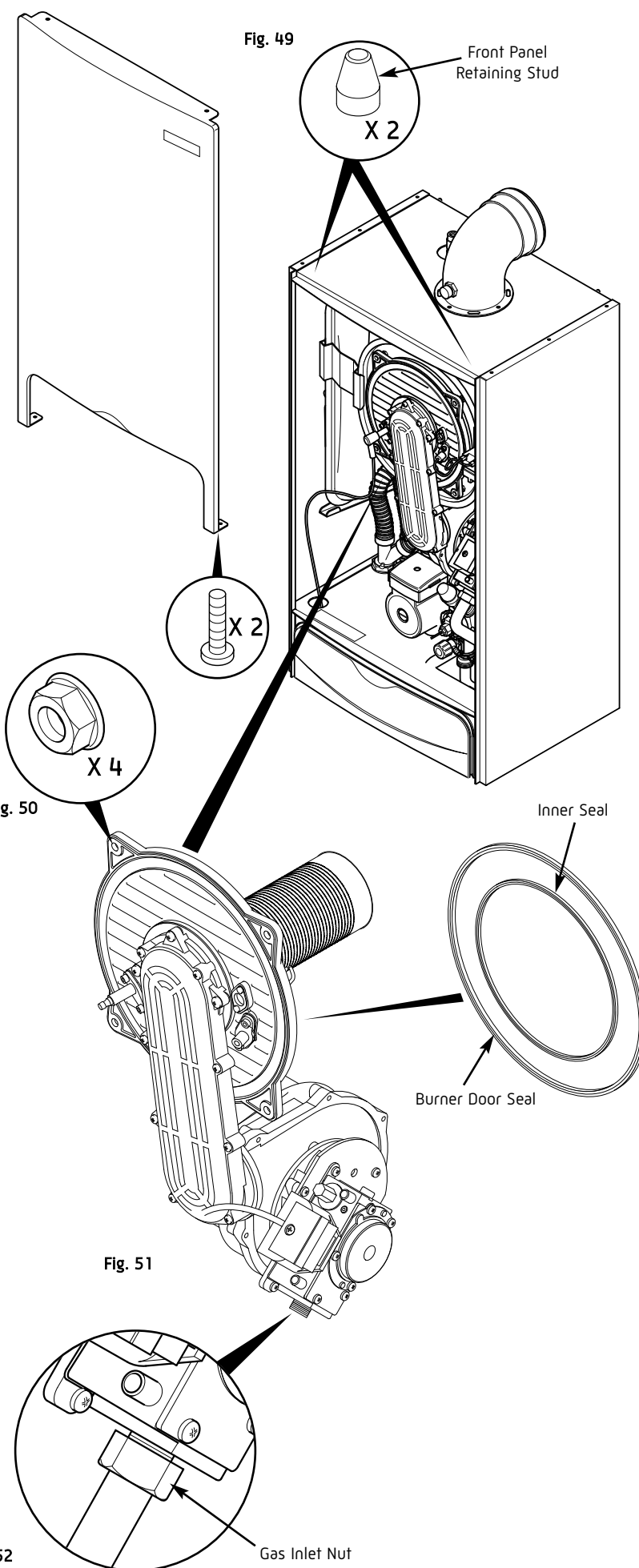

8.0 FLUE OPTIONS



8.8 Kit E Chimney Flue Liner Kit (B23) – Part no. 956082

This kit is suitable for open flue application in accordance with BS5440 where a room sealed flue installation is impractical. The kit comprises of a flue adaptor from the appliance to the chimney, a flexible plastic flue liner with connection parts and chimney terminal (see Fig. 27). Where an open flue system is used, then an air vent must be provided in the same room or internal space as the flue duct air inlet, see section 7.3. For installation details refer to the flue kit instructions. Maximum flue resistive length = 30m.

A flue system can be built up from the components detailed in table 8.10, but the total flue resistance must not exceed the maximum stated.

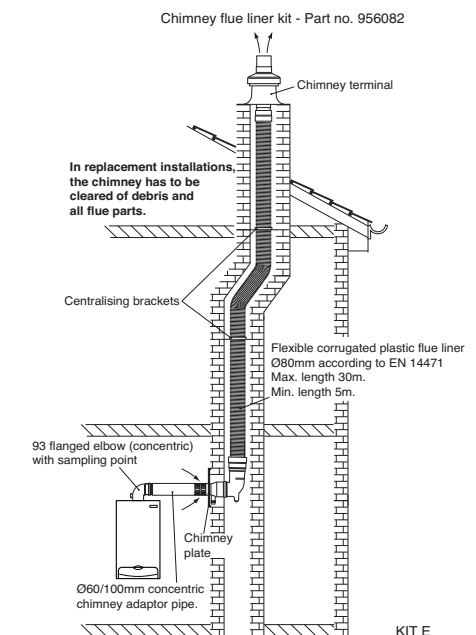

Fig. 27

8.9 Kit F: Twin Flue System (C53) – Part no. 956080

This flue system kit is designed for installations where the air intake position is different than the flue duct exit point. The kit comprises of a twin adaptor from which the air intake is taken from the adjacent outside wall (see Fig. 28) and the flue duct is routed vertically through the roof.

It has to be noted that the flue duct is under pressure when the appliance is in operation and the duct can leak poisonous carbon monoxide if the duct components are not correctly assembled. It is **not** recommended to route the flue duct through living space areas, i.e. bedrooms, living rooms etc. For installation details refer to the instructions provided with the twin flued kit. For C53 flue systems the terminal for the supply of combustion air and for the evacuation of combustion products shall not be installed on opposite walls of the building.

Maximum flue resistance permitted for a twin flued system = 52 Pa

Minimum flue resistance permitted for a twin flued system = 23.5 Pa

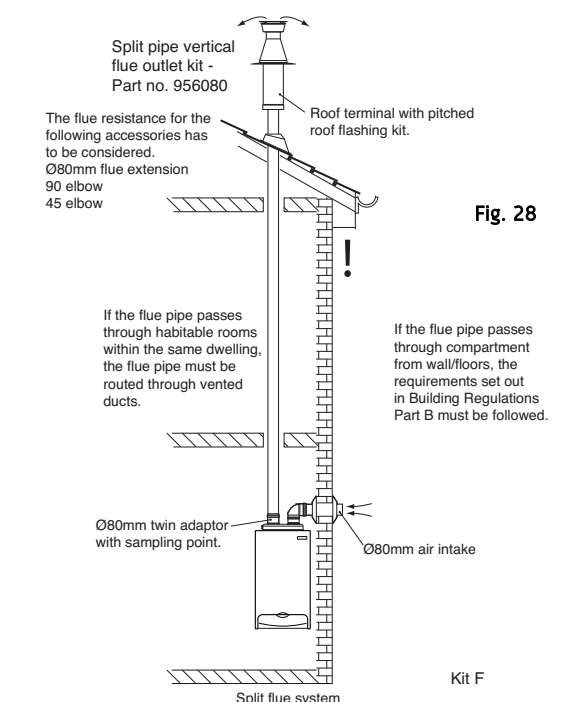

Fig. 28

Flue Component	Flue Resistance (Pa)	Part Number
Twin Flue Adaptor (required)	9.5	-
Air Inlet Terminal (required)	3	-
Chimney Terminal (required)	0.5	-
80 mm dia straight duct 1 metre	1	956101
80 mm dia straight duct 2 metre	2	956102
90° Elbow (80/80)	8	956100
45° Elbow (80/80)	4	956099

A flue system can be built up from the components detailed in the table, but the total flue resistance must not exceed the maximum stated.

8.0 FLUE OPTIONS



8.10 FLUE LENGTHS

Length supplied in standard kit - horizontal		815mm
Max horizontal length (from boiler to chimney - 60/100mm)		2000mm
Min horizontal length (from boiler to chimney - 60/100mm)		100mm
Max vertical length (from boiler to chimney - 60/100mm)		2000mm
Min vertical length (from boiler to chimney - 60/100mm)		200mm
Length supplied in standard kit - vertical (available in 10m, 20m and 30m length)		N/A
Flexitube must be purchased as an accessory to complete the kit (see below)		
Flexitube min length		5m
Flexitube max length		30m
Accessories		
Description	Part No.	Equivalent Length
Horizontal - 60/100 Accessories		
Flue extension duct - 500mm	956092	450mm
Flue extension duct - 1000mm (incl. 1 x support bracket)	956093	950mm
93° extension elbow	956091	1550mm
45° extension elbow (pair)	956090	775mm
Air inlet duct - included in kit	N/A	N/A
Straight adaptor (60/80) - included in kit	N/A	N/A
91.5° adaptor elbow (80/80) - included in kit	N/A	N/A
Support bracket - 100mm	840517	N/A
93° flanged elbow - included in kit	956082	N/A
Vertical turret socket	956087	N/A
Vertical - Accessories		
Flexi tube - 10m	956110	10m
Flexi tube - 20m	956111	20m
Flexi tube - 30m	956112	30m
Straight duct (80) - included in kit	N/A	N/A
Chimney terminal - included in kit	N/A	N/A

Note: Equivalent length information only required for coaxial flue parts.
The corrugated (Flexi tube) flue parts are fixed and all parts are required for every application.

8.11 Additional Concentric Flue Kit Accessories

The following additional concentric kit accessories are available as optional extras.

Flue Extension Ducts - 1000 mm (956093) and 500 mm (956092), (each duct extends the flue length by up to 950 mm and 450 mm respectively).

93° Extension Elbow (956091) - Allows an additional bend in the flue, and has an 'equivalent length' of 1550 mm. This elbow is mechanically different from the flanged elbow supplied as standard with the appliance, but has the same equivalent length.

45° Extension Elbow (956090) - Allows an additional bend in the flue and has an 'equivalent length' of 775 mm.

Vertical Turret Socket (956087) - For use with elevated horizontal flues and vertical terminals.

Vertical Roof Terminal - For use where an external wall is not available, or where it is desirable to route the ducts vertically.

For installation details refer to the instructions provided with the individual flue kits.

These optional kits may be used with the standard flue kits to produce an extensive range of flue options, providing that the following rules are strictly obeyed.

a) The maximum/minimum permissible length of the room sealed flue system are:
Horizontal flue terminal (all orientations)
maximum 10000 mm

Horizontal flue terminal (rear exit)
minimum 250 mm

Vertical flue terminal maximum 12000 mm

Vertical flue terminal minimum 600 mm

The 'equivalent' flue length must not exceed the maximum values stated.

b) The standard terminal must be fitted horizontally; horizontal ducts must have a continuous fall towards the appliance of 1.5° to 3°. This ensures condensate runs back into the appliance from the flue system. The vertical terminal must always be used if a vertical outlet is required.

c) The concentric flue system must use either a flanged elbow or a vertical flue turret socket at the entry/exit to the appliance.

d) All joints must be correctly made and secured in accordance with the installation instructions. When cutting ducts, avoid swarf, uneven and sharp edges to maintain duct integrity.

Refer to Fig. 19 & 20 to determine which option kits are required before commencing the installation. Instructions for installing the appliance with a horizontal flue and straight extension ducts are included in the main text of these instructions (section 9.5).

12.0 SERVICING AND MAINTENANCE



12.2 COMBUSTION CHECKS

COMBUSTION CHECKS AT MAXIMUM RATE

9. Set the boiler to Maximum gas rate.

10. Check the Carbon Monoxide (CO) and Carbon Dioxide (CO₂) readings are within the range quoted in the tables opposite (Table 2).

11. If the combustion value(s) is outside the values specified in Tables 1 and 2 and the integrity of the full flue system and combustion circuit seals, the inlet gas pressure and gas rate have been verified, it is possible to make an adjustment to the combustion settings by adjustment of the air/gas ratio valve. See Section 12.3 Adjustment of the Gas Valve.

12.3 ADJUSTMENT OF THE GAS/AIR RATIO VALVE

COMBUSTION SETTING ADJUSTMENT

1. It is only possible to adjust the valve at Maximum rate. No adjustment at Minimum rate is allowed.

2. If the maximum rate setting is adjusted, then the combustion values must be checked at minimum rate.

NOTE: DO NOT ATTEMPT TO ADJUST THE GAS/AIR RATIO VALVE UNLESS;

- The person carrying out the measurement has been assessed as competent in the use of a flue gas analyser and the interpretation of the results.
- The flue gas analyser used, meets the requirements of BS7927 or BS-EN50379-3.
- The flue gas analyser is calibrated in accordance with the manufacturers requirements.

3. At Maximum Gas Rate; put the appliance into Service Mode at Maximum Gas Rate (see Section 11.2).

4. Wait 5 minutes to allow the boiler to stabilise.

5. If the Carbon Dioxide (CO₂) level is outside the required values given in Section 12.2 (Table 2) then adjust the throttle screw (Fig. 48) until the CO₂ is at the correct setting level. See Table 4. Clockwise to decrease CO₂, anti-clockwise to increase CO₂.

NOTE: Only turn the throttle in small steps of **no more than 1/8th of a turn** and wait 1 minute after each adjustment for the combustion reading to stabilise.

IMPORTANT: After any adjustment of the gas valve, it is essential to check the combustion levels at minimum gas rate (Table 1). If the Carbon Monoxide or Carbon Dioxide levels are outside the range quoted, call Dimplex Boilers Ltd Technical Helpline on 0844 3711121. If in doubt ASK!

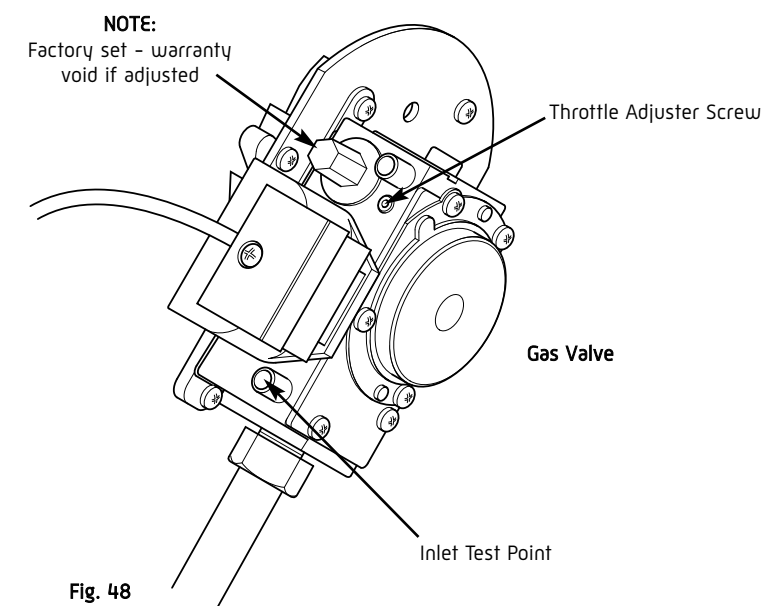

Fig. 48

Carbon Dioxide (CO ₂) acceptable setting level at Maximum Gas Rate after 5 minutes operation		
Boiler Model	Natural Gas %	LPG (Propane) %
System 18	9.0	11.0
System 30	9.0	10.7

Table 4

12.0 SERVICING AND MAINTENANCE



12.1 ROUTINE SERVICING AND ALL MAINTENANCE THAT INVOLVES THE EXCHANGE OF PART OF THE COMBUSTION CIRCUIT

1. During routine servicing, e.g. an annual service check, and after all maintenance that involves the exchange of parts of the combustion circuit, we recommend that (in this order) the integrity of the full flue system and combustion circuit seals, the inlet gas pressure, gas rate and combustion performance is verified.

NOTE: The combustion circuit on this appliance comprises of the PCB, fan, air/gas ratio valve, burner, burner door, combustion box door, injector and flue system.

2. To ensure continued safe and efficient operation of the appliance it is recommended that the boiler is serviced at least annually. Servicing must be performed by a competent person. BS 7967-1 gives guidance on identifying and managing sources of fumes, smells, spillage/leakage of combustion products and carbon monoxide detector activation.

Safety Checks

On any service visit always check:

- Condition of flue system, both air and combustion products ducts.
- Condition of seals and joints.
- For evidence of leakage of combustion products.
- For evidence of heat staining.
- For operation at maximum heat input.
- The general condition of the boiler and its components.

12.2 COMBUSTION CHECKS

1. Combustion checks must be carried out with the outercase fitted.

2. Remove the sampling cap from the boiler flue elbow or boiler vertical flue adaptor.

3. Insert the probe from the portable electronic combustion analyser into the sampling point.

4. With the appliance operational, connect the flue gas analyser to the flue sampling point as shown in Fig. 47.

NOTE: The outercase must be fitted for all combustion checks.

5. With the boiler at minimum rate and then at maximum rate (allowing the combustion to stabilise at each rate before taking a reading) carry out the combustion checks as follows:

COMBUSTION CHECKS AT MINIMUM RATE

6. The combustion values at minimum gas rate and maximum gas rate must be checked using a suitable calibrated flue gas analyser. Further guidance is detailed in BS7967 parts 1 to 4.

7. Set the boiler into Service Mode at Min Rate (see section 11.1).

8. Check the Carbon Monoxide (CO) and Carbon Dioxide (CO₂) readings are within the range quoted in the tables opposite (Table 1).

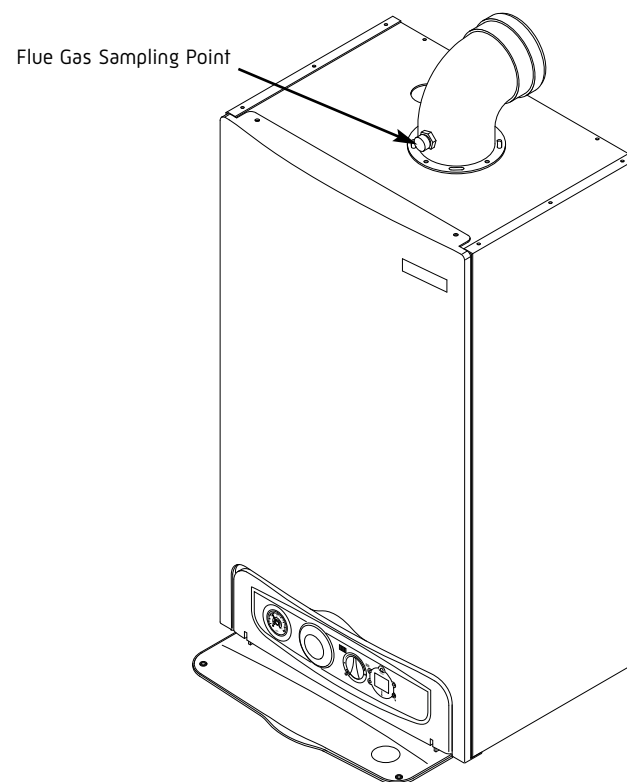

Fig. 47

Minimum Gas Rate				
	NG		LPG	
Boiler Model (kW)	Carbon Monoxide CO p.p.m	Carbon Dioxide CO ₂ %	Carbon Monoxide CO p.p.m	Carbon Dioxide CO ₂ %
18	0 - 40	8.5 - 8.9	80 - 160	10.4 - 10.8
30	0 - 40	8.7 - 9.1	80 - 160	10.3 - 10.7

Table 1

Maximum Gas Rate				
	NG		LPG	
Boiler Model (kW)	Carbon Monoxide CO p.p.m	Carbon Dioxide CO ₂ %	Carbon Monoxide CO p.p.m	Carbon Dioxide CO ₂ %
18	15 - 60	8.8 - 9.2	80 - 160	10.8 - 11.2
30	15 - 60	8.8 - 9.2	80 - 160	10.5 - 10.9

Table 2

9.0 INSTALLATION



9.1 UNPACKING & INITIAL PREPARATION

The gas supply, gas type and pressure must be checked for suitability before connection

1. Remove the top cardboard tray from the carton.

2. The wall fixing jig is packed in its own cardboard sleeve. Carefully slide this out of the carton.

3. To avoid scratching the boiler outercase, keep the outer carton in place.

4. After reviewing the site requirements (see Section 7.0), position the fixing template on the wall ensuring it is level both horizontally and vertically.

5. Mark the position of the fixing holes for the wall plate and boiler lower fixing holes.

6. Mark the position of the centre of the flue hole (rear exit). For side flue exit, mark as shown (Fig. 4).

7. If required, mark the position of the gas and water pipes. Remove the template.

8. Cut the hole for the flue (minimum diameter 110mm).

9. Drill the wall as previously marked to accept the wall plugs supplied. Secure the wall fixing jig using the fixing screws.

10. Using a spirit level ensure that the fixing jig is level before finally tightening the screws.

11. Flush and clean the system using an appropriate cleanser (Fig. 30).

12. Connect the gas and water pipes to the valves on the wall fixing jig.

13. Fit the filling loop as described in the instructions supplied with it.

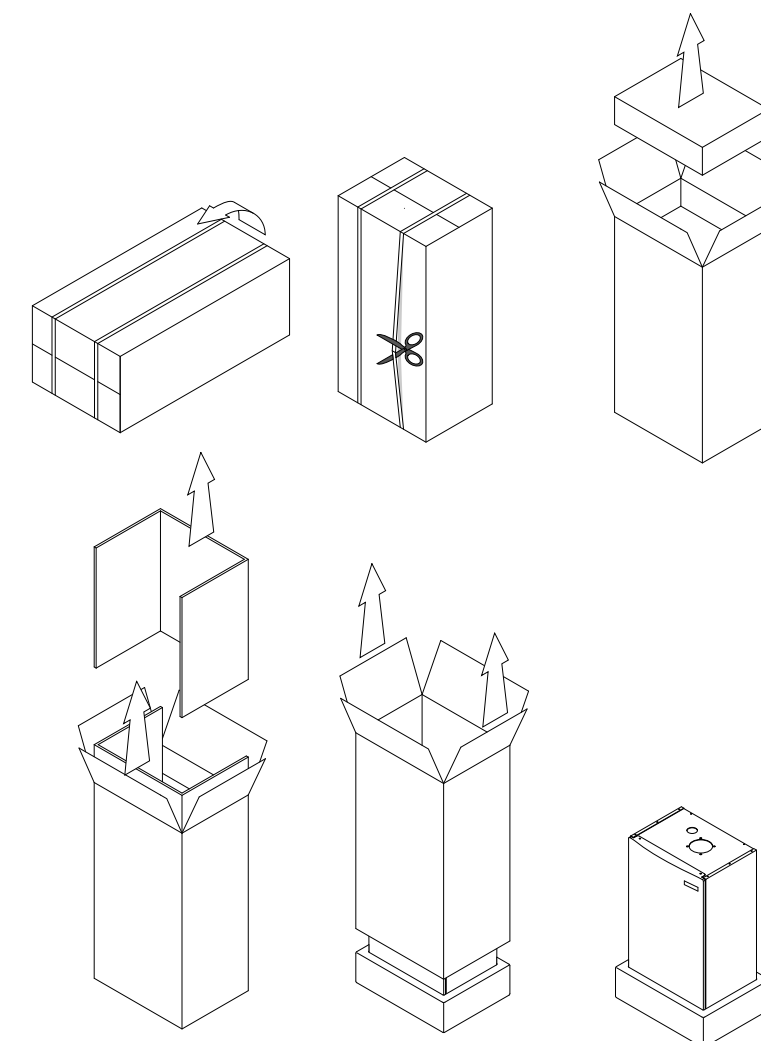

Fig. 29

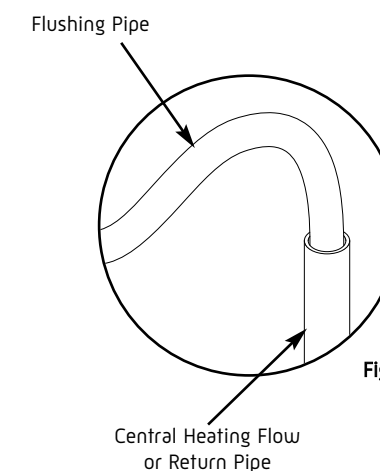

Fig. 30

9.0 INSTALLATION
9.2 FITTING THE BOILER

1. Remove the sealing caps from the boiler connections.

NOTE: A small amount of water may drain from the boiler once the caps are removed.

2. Check the sealing washers are located correctly in the taps on the wall jig.
3. Lift the boiler as indicated by the shaded areas. The boiler should be lifted by TWO PEOPLE. Engage the slots at the top rear of the boiler on the wall plate (Fig. 31) (see **Safe Manual Handling** page 6).
4. Ensure the boiler is correctly located on the wall jig and the connections align. Tighten all the connections.

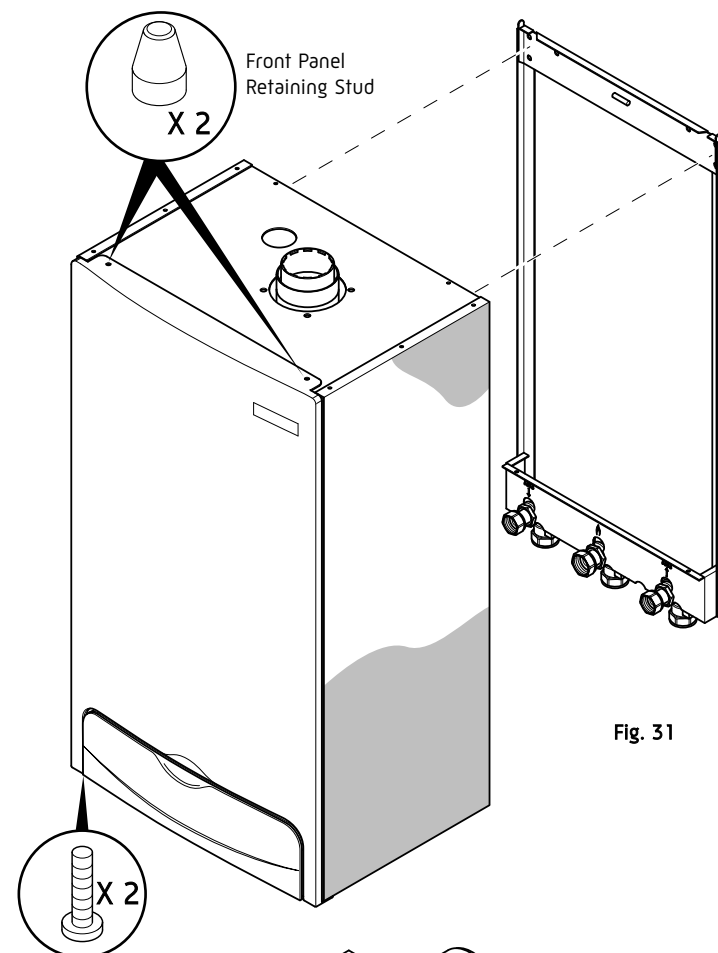

Fig. 31

9.3 FITTING THE PRESSURE RELIEF DISCHARGE PIPE

1. Remove the two screws securing the front panel to the underside of the boiler. Rotate the bottom of the panel out slightly and lift the panel upwards off its retaining studs on top of the appliance.
2. Determine the route of the discharge pipe.
3. Taking care not to disturb the case sealing grommet, the pipework must be at least 15mm diameter and run continuously downwards to a discharge point outside the building.
4. Complete the discharge pipework and route it to the outside discharge point.

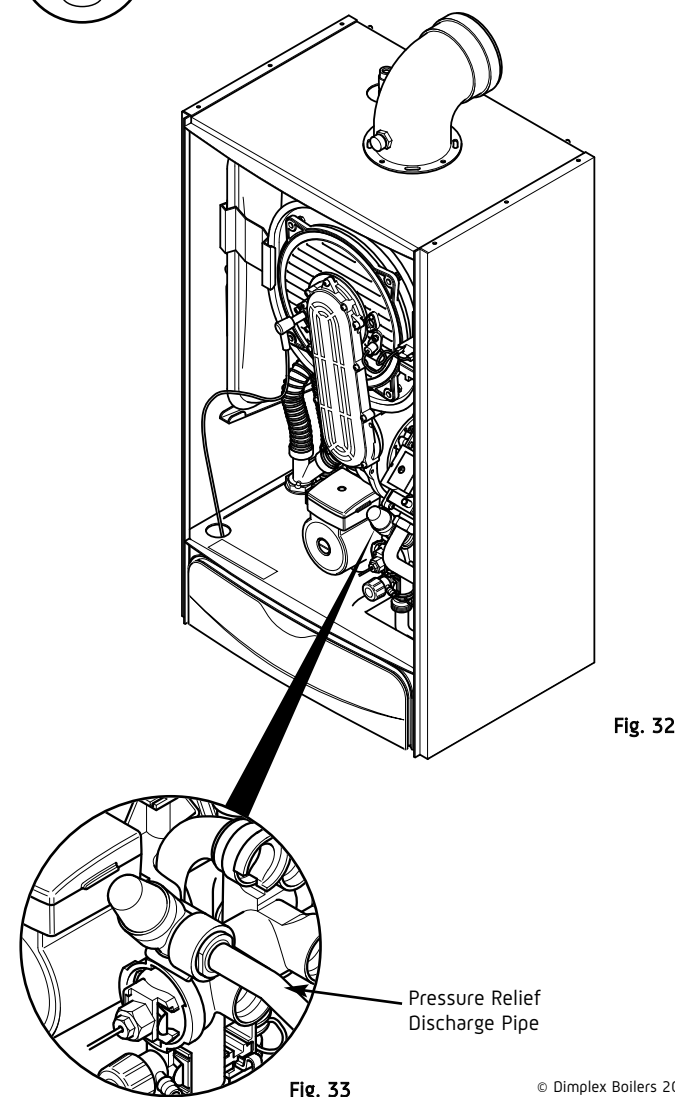

Fig. 32

9.4 CONDENSATE DRAIN

1. Connect the condensate drain to the trap outlet pipe.

Ensure the discharge of condensate complies with any national or local regulations in force (see British Gas "Guidance Notes for the Installation of Domestic Gas Condensing Boilers").

2. The connection will accept 21.5 - 22mm plastic overflow pipe which should generally discharge internally into the household drainage system. If this is not possible, discharge into an outside drain is acceptable.

Fig. 33

© Dimplex Boilers 2008

11.0 SERVICE MODE

NOTE: Service Mode automatically stops after 10 minutes and the boiler returns to normal operation.

11.1 TO SET THE BOILER AT MINIMUM GAS RATE

1. Turn the CH knob fully clockwise - Note the knob will turn past the maximum temperature mark (Fig. 45).
2. The CH light will flash continuously - the boiler is now running at minimum rate.

11.2 TO SET THE BOILER AT MAXIMUM GAS RATE

1. Set the boiler into Service Mode at Minimum Rate.
2. Whilst in Service Mode at Min Rate, turn the CH knob to 12 'O' clock position and then back to fully clockwise (past the maximum temperature indicator) within 3 seconds. The boiler will now run at maximum gas rate for 10 minutes.
3. To exit Service Mode, turn the CH knob anti-clockwise to the temperature previously set by the customer. The CH light will now stop flashing.

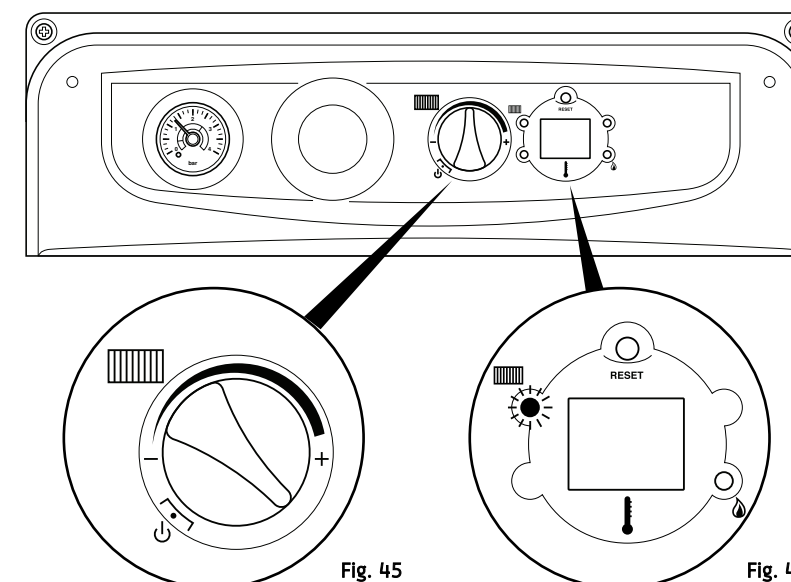

Fig. 45

Fig. 46

10.0 COMMISSIONING



10.2 FACTORY SETTINGS

NOTE: This boiler is supplied factory set for operation on natural gas. No further adjustments of the air/gas ratio valve or measurement of the combustion performance are necessary at the time of installation and commissioning. This is provided the appliance has been installed according to these instructions and the inlet gas pressure is within our specification.

10.3 INLET PRESSURE AND GAS RATE CHECKS

1. With the boiler firing at maximum gas rate, check that the inlet pressure at the appliance is 19mbar +/- 1mbar when measured at the inlet pressure test point (Fig. 44). To set the boiler to maximum gas rate see section 11.0 (Service Mode).

2. Check the maximum and minimum gas rate at the gas meter according to the table below using a stopwatch.

Gas Rates (Natural Gas) after 5 minutes from cold				
Boiler Model	Maximum Rate		Minimum Rate	
	m ³ /h	ft ³ /h	m ³ /h	ft ³ /h
System 18	1.95	68.8	0.57	20.1
System 30	3.2	113	0.8	28.2

10.4 COMBUSTION CHECKS DURING COMMISSIONING

1. On completion of the gas inlet pressure and gas rate checks, it is necessary to check the following:

- The appliance installation conforms to these instructions.
- The installation and integrity of the full flue system including the seals in the flue pipes.
- The boiler combustion circuit, including the burner door seal, combustion door seal.

NOTE: If any doubts exist over the above checks then the combustion of the appliance can be measured as described in Section 12.0 of these instructions providing:

- The person carrying out the measurement has been assessed as competent in the use of a flue gas analyser and the interpretation of the results.
- The flue gas analyser used, meets the requirements of BS7927 or BS-EN50379-3.
- The flue gas analyser is calibrated in accordance with the manufacturers requirements.

2. The recorded combustion values should be compared with the values in Table 1 and Table 2 (see Section 12.2).

3. If the combustion value(s) is outside the values specified in Section 12.2 (Tables 1 & 2), do not attempt to adjust the air/gas ratio valve, please ring the helpline number - **0844 371 1121. If in doubt - ASK.**

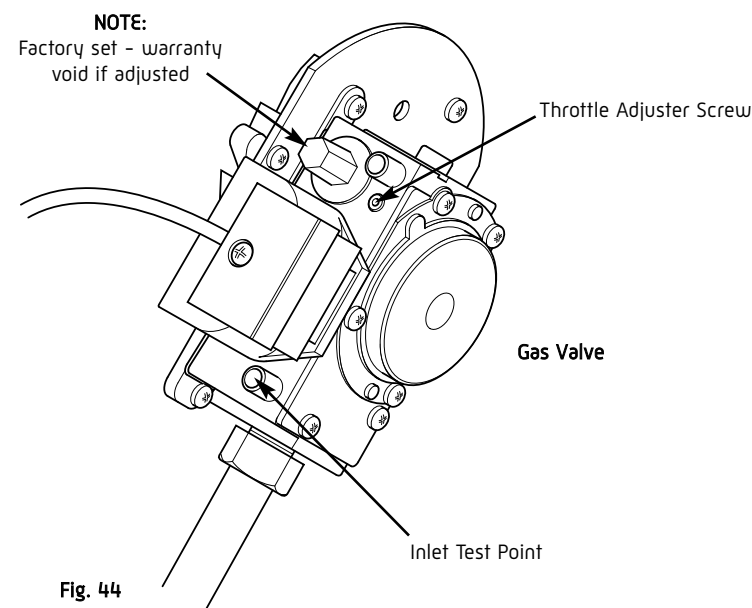

Fig. 44

9.0 INSTALLATION



9.5 FITTING THE FLUE

HORIZONTAL TELESCOPIC FLUE

1. For correct flue installation please refer to the installation instructions that are provided with the individual flue kit as described in sections 7 & 8.

2. Measure the required flue length as shown in Fig. 34. Refer to section 8 to determine whether any extension kits are required. Installations using only the standard ducts or standard ducts with straight extensions are described in this section. Installation instructions for all other flue systems are included in the various flue kits.

3. Ensure that all (inner and outer tube) sealing rings are provided and assemble the air/flue ducts as shown in the flue instructions.

4. Ensure that the flue and air seals are correctly fitted before assembly and that each section is fully engaged.

NOTE: NEVER CUT THE SWAGED END. Where necessary the plain ends of the extension ducts may be cut. Always ensure that the cut is square and free of burrs or debris. It is essential that the terminal is fitted the correct way up. See flue kit instructions (i.e. rain shield at the top).

INSTALLING THE AIR/FLUE DUCT FROM INSIDE THE ROOM

Detailed installation instructions are included in the flue kit. (Flue hole diameter 130mm).

1. Push the terminal through the wall taking care to ensure that the terminal is the correct way round and the external wall-sealing ring does not become dislodged.

2. Assemble the flue system extension ducts as necessary, referring to Fig. 35.

3. Pull the flue system towards the appliance to seat the external sealing ring against the outside wall, ensuring that the duct joints are not disturbed.

4. Use the internal sealing ring to make good the internal hole and check that the terminal is correctly located on the outside wall. Where possible this should be visually checked from outside the building (Fig. 35).

5. Finally locate and secure the elbow to the appliance using the four screws provided.

INSTALLING THE AIR/FLUE DUCT FROM OUTSIDE THE BUILDING

Detailed installation instructions are included in the flue kit. Flue hole diameter 100mm - 110mm.

1. Secure the flue elbow with seal to the appliance using 4 screws.

2. Fit the external wall sealing ring over the flue and then from outside the building, push the flue system through the wall taking care to ensure that the terminal is the correct way around.

3. Loosely fit the internal wall sealing ring over the inside end of the flue.

4. Assemble the flue system extension ducts as necessary referring to the flue kit instructions and fit to the elbow.

5. Fit the flue terminal to the flue system, ensuring that the duct joints are not disturbed and that the external sealing ring is seated against the outside wall.

6. Finally use the internal sealing ring to make good the internal hole. Check that the external wall sealing ring and the terminal is correctly located on the outside wall.

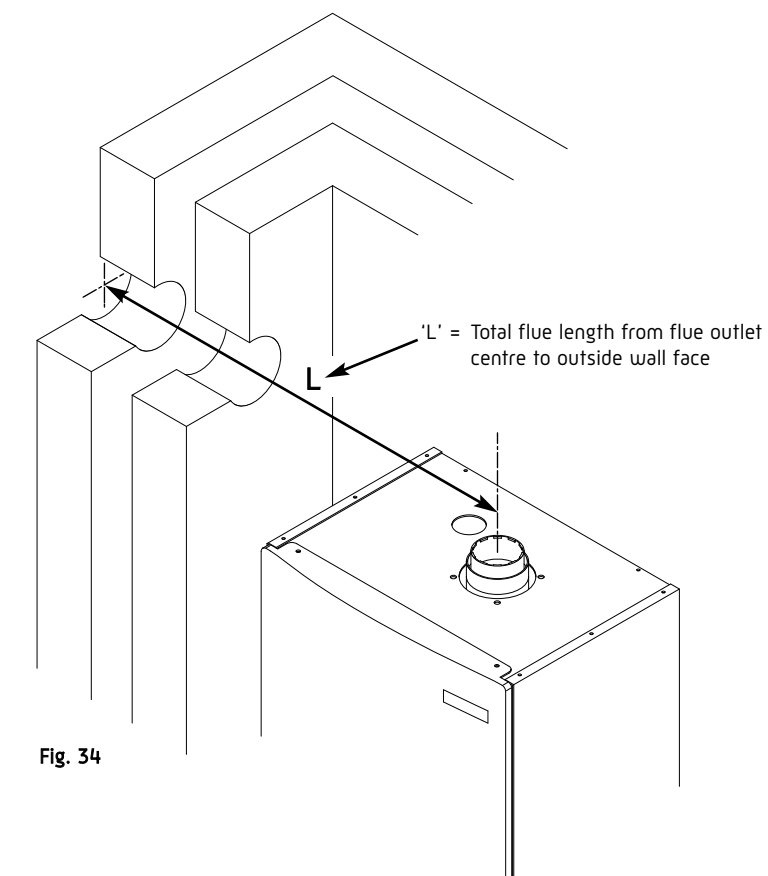

Fig. 34

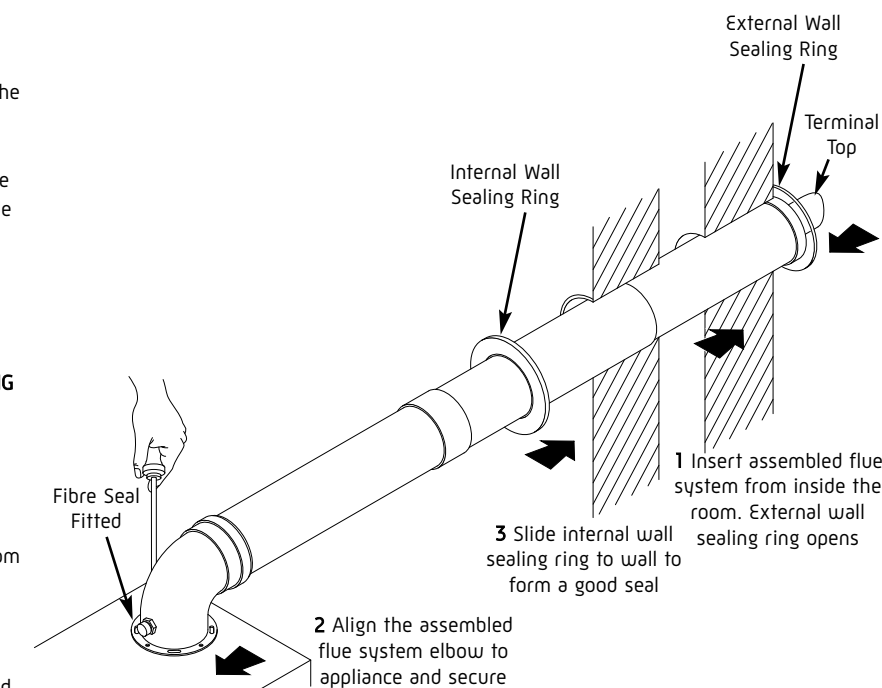

Fig. 35

9.0 INSTALLATION

9.6 MAKING THE ELECTRICAL CONNECTIONS

The boiler is fitted with a 1.5m length of 3 core cable. This can be connected to the fused 3A 230V 50Hz supply.

To connect an external control proceed as follows:-

1. Lower the drop down door.
2. Remove the two screws holding the controls box and ease the box away from the boiler. The electrical connections are made at the left hand side on the rear of this box.
3. Slacken the cable clamp on the terminal block (Fig. 36). Insert the external control wiring through the clamp and route it to the terminal block. Tighten the cable clamp.
4. Refer to the instructions supplied with the control.

IMPORTANT: The room thermostat **MUST** be suitable for 230V switching.

Ensure that the external control input cable (s) have sufficient slack to allow the control box to drop down.

5. Route external control cables away through the mains cable grommet supplied.

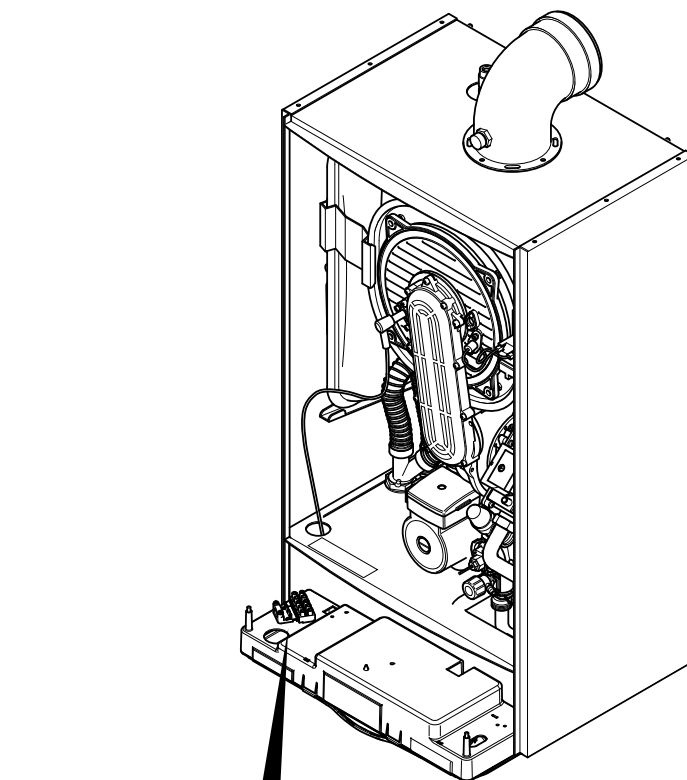
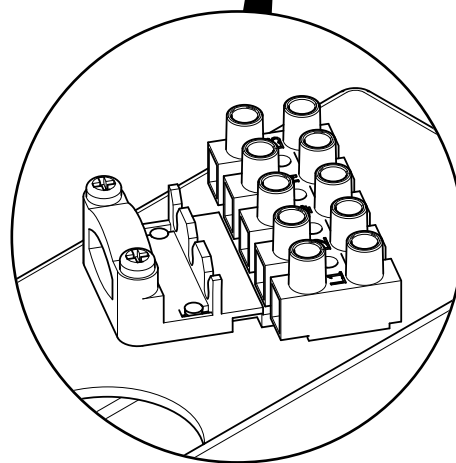

Fig. 36



9.7 PRELIMINARY ELECTRICAL CHECKS

1. Prior to commissioning the boiler preliminary electrical system checks should be carried out.
2. These should be performed using a suitable meter, and include checks for Earth Continuity, Resistance to Earth, Short Circuit and Polarity.

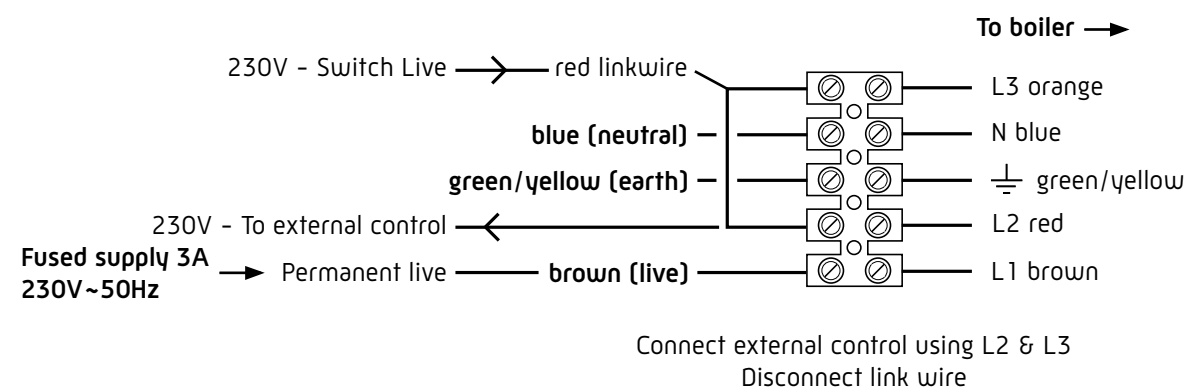

Fig. 37

10.0 COMMISSIONING

10.1 COMMISSIONING THE BOILER

IMPORTANT: The air vent on top of the boiler must be OPEN when filling the system. Attach a tube to the air vent to safely collect any excess water (Fig. 38).

Gas Soundness

1. Ensure the gas service cock on the boiler is turned on (Fig. 40). The entire gas installation must be tested for gas tightness and purged in accordance with BS6891.

2. Open the service cocks to the CH flow and CH return supplies.

3. Connect the filling loop and fill and vent the CH system.

NOTE: Ensure the boiler is completely vented using the manual air vent on top of the boiler.

4. Drain, flush and refill the boiler and system in accordance with BS7593 (Fig. 30).

NOTE: Failure to flush the system and to add inhibitor will invalidate the appliance warranty.

5. Pressurise the system to 1.5 bar (Fig. 42).

Electrical Safety Checks on the Controls System and Boiler

6. Carry out earth continuity, resistance to earth, short circuit and polarity checks using a suitable meter.
7. Switch on the electricity supply to the boiler.
8. Set the controls to call for heat. The boiler will now operate. Check the system for correct operation.
9. Replace the outer door and two securing screws.

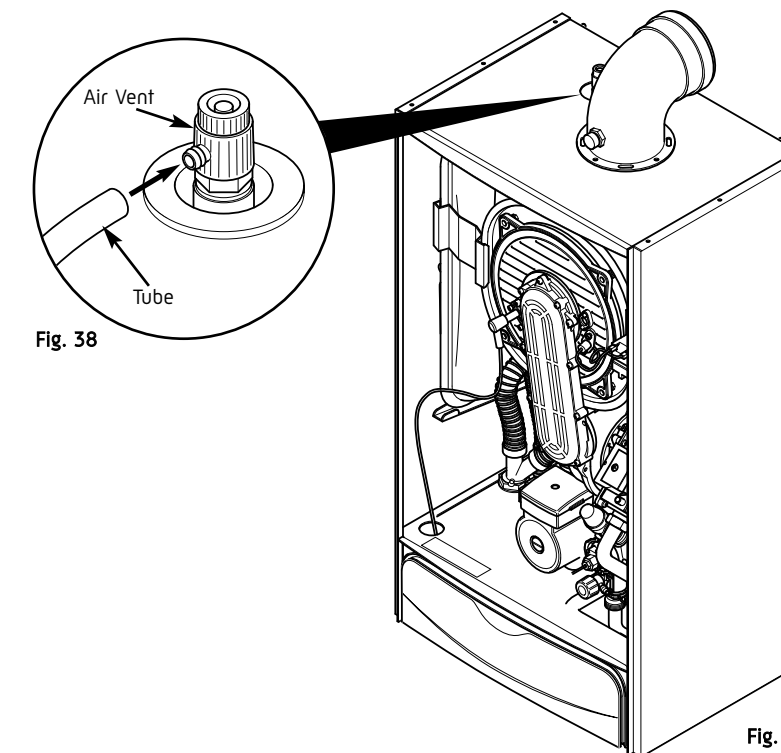

Fig. 38

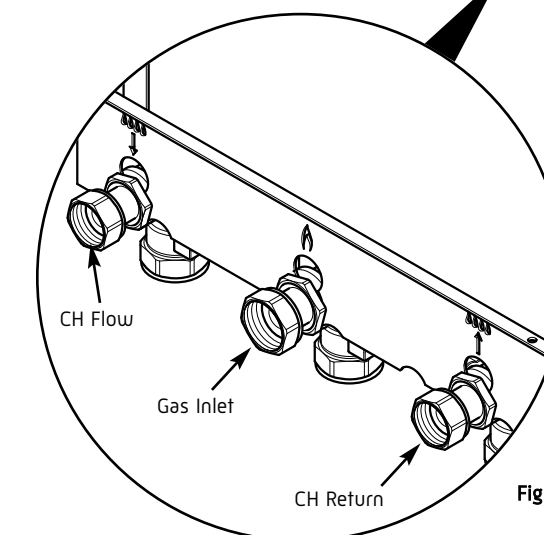

Fig. 40

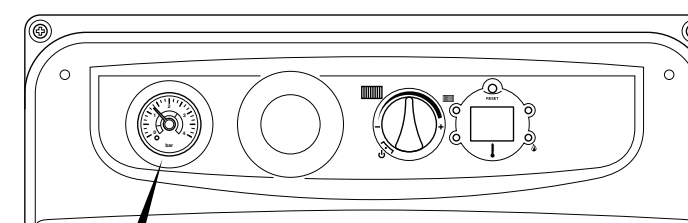

Fig. 43

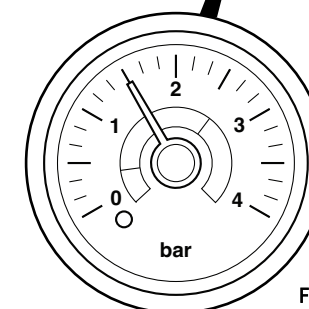

Fig. 42

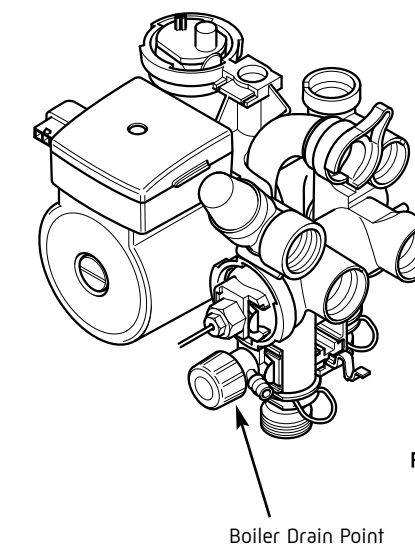

Fig. 41