

**Chaffoteaux
et Maury**

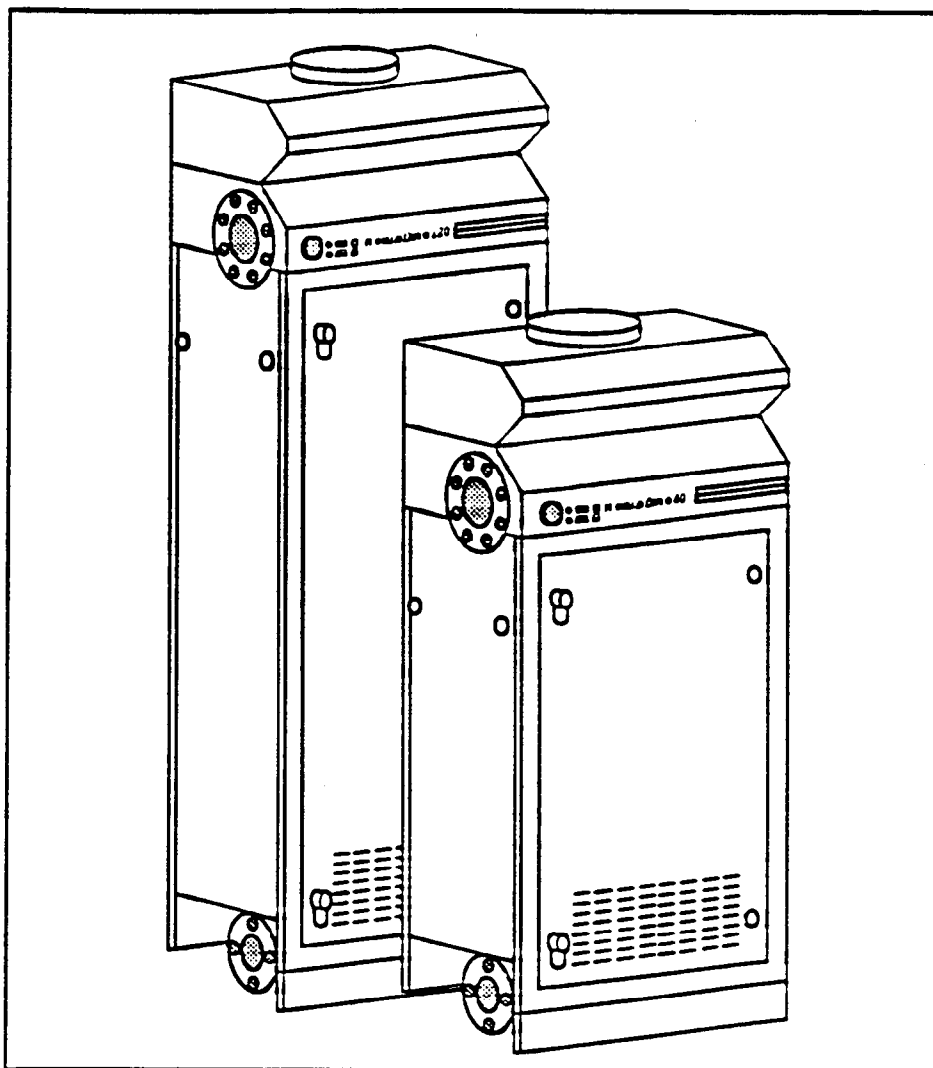

MODULOFLAME 280 & 420

COMMERCIAL OPEN FLUED BOILER RANGE



CE

INSTALLATION INSTRUCTIONS

Chaffoteaux et Maury



CHAFFOTEAUX ET MAURY Limited
Trench lock, Trench,
Telford, Shropshire TF1 4SZ
Telephone : Telford (0952) 222727
Telefax : (0952) 243493

Ref. : 92220-142 - 02/96

Moduloflame 280 & 420
cat. II 2H3P

STATUTORY REQUIREMENTS

The installation of this appliance must be carried out by a CORGI Registered person or other competent person and in accordance with the requirements of the current editions of the Gas Safety (Installation and Use) Regulations, the IEE Wiring Regulations and local Water Authority By-Laws. It should also comply with the following documents:

The Building Regulation:

- The Gas Safety (Installation and Use) Regulations
- The Public Health Act -1936
- British Gas Publications - Flues for Commercial and Industrial Gas Fired Boilers and Air Heaters (1979) IM/11

British Standards:

- BS 4505: Part 1 - Flanges and Bolting for pipes, valves and fittings
- BS 6644 Installation of gas-fired hot water boilers of rated inputs between 60kW and 2MW

Codes of Practice

- BS CP 331: Part 3 - "Gas supplies to appliances"
- BS CP 341 300 - 307 Central Heating by low pressure hot water
- BS CP 342 - Centralised hot water supply:
 - Part 1 - Individual dwellings
 - Part 2 - Buildings other than individual dwellings
- BS 6759 Safety Valves
- BS 4076 Specifications for steel chimneys

To comply with the Control of Substances Harmful to Health Regulation 1988 we are required to provide information on the following substance that is contained within the appliance.

Description: Combustion Chamber Lining

Material: Alumino Silicone Fibre

Precautions: During servicing, keep the dust generation to a minimum and avoid inhaling any dust and contact with the skin and eyes. Normal handling and use will not present any discomfort, although some people with a history of skin complaints may be susceptible to irritation. When disposing of the lining, ensure that it is securely wrapped and wash hands after contact.

GUARANTEE

The manufacturer's guarantee is for 12 months from the date of purchase. The guarantee is voidable if the appliance is not installed in accordance with the recommendations made herein or in a manner not approved by the manufacturer.

CUSTOMER CARE

Chaffoteaux et Maury Ltd., as a leading manufacturer of domestic and commercial water heating appliances, is committed to providing high quality products and a high quality after sales service. If it is necessary to contact an engineer, then telephone your local Chaffoteaux Service Centre. The number can be obtained from the leaflet enclosed in the customer care pack with your boiler or by telephoning the Chaffoteaux Customer Services Department at Telford.

Advice on installation or servicing can also be obtained by contacting the Chaffoteaux Customer Services Department at Telford.

CUSTOMER SERVICES DEPARTMENT

Tel: 01952 222288

Fax: 01952 260915

CONTENTS

Statutory requirements	2
Guarantee	2
Customer care	2
Introduction	4
Description	4
Technical data	5
Dimensions	5
Installation and operation	6
Operation	6
System design	6
Flow rates	6
Operating pressures	6
Assembly	6
Accessories	6
Layout	6
Positioning	6
Connecting to system	7
Electrical connections	7
Controlling modules or multiple boilers using external controls	7
Commissioning	8
Filling and purging	8
Bringing into operation	8
Gas rate adjustment	8
Post commissioning	8
Handing over to user	8
Routine servicing	9
Suggested sequence for servicing	9
Preliminary checks	9
Replacing components	9
Fault finding charts	10
Wiring diagram	11
Short part list.	11

Installation Instructions

INTRODUCTION

The Moduloflame 280 and Moduloflame 420 are low water content floor standing open flue boilers. They are intended for commercial applications and are suitable for both open vented or sealed systems. Each boiler comprises two or three modules, each module having its own water circulating pump, gas valve, burner and heat exchanger assemblies. The modules each have an output of 40 kW and are mounted vertically one above the other providing a high output to floor area ratio. The boilers are of a lightweight construction and so provide a high output to weight ratio. The Moduloflame 280 and 420 models are supplied with flanged connections to allow for the simple connection to system pipework or to other Moduloflame boilers of the same size to make up banks of boilers and thereby multiples of the output of each boiler. Each boiler has an integral flue duct and is contained in a pre-assembled case with a single door that can be reversed to enable easy access for installation and maintenance. Each module can be turned off and serviced independently and all components are accessible and removable from the front. Optional side panels are available as accessories.

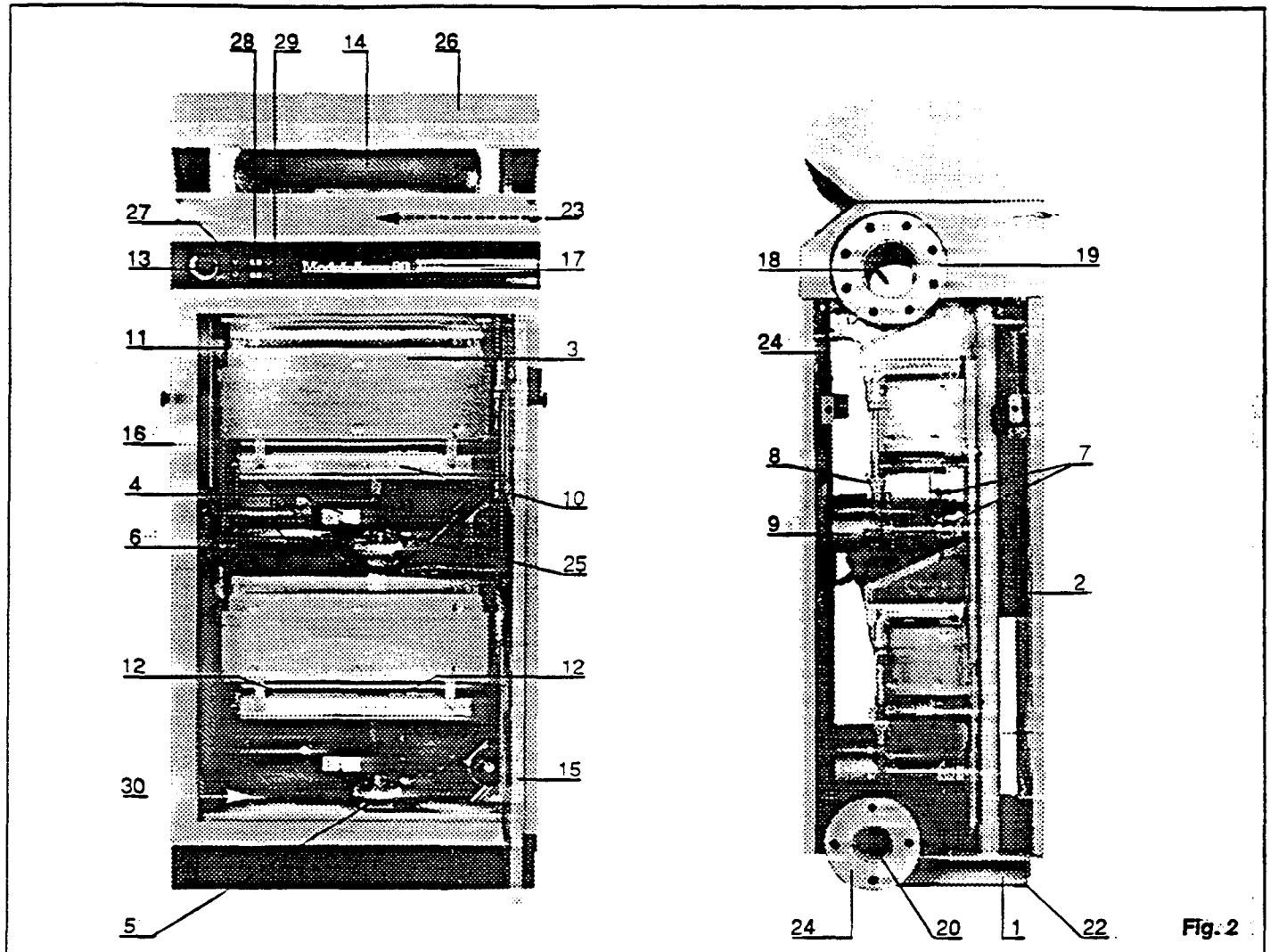

DESCRIPTION

- | | | |
|------------------------------------------------------------------------------------------------------------------------------------------------------------------------------------------------------------------------------------------------------------------------------------------------------------------------------------------------------------------------------------------------------------------------------|------------------------------------------------------------------------------------------------------------------------------------------------------------------------------------------------------------------------------------------------------------------------------------------------------------------------------------------------------------------------------------------------------------------------------------------------------------------------------------------------------------------------|-------------------------------------------------------------------------------------------------------------------------------------------------------------------------------------------------------------------------------------------------------------------------------------------------------------------------------------------------------------------------------------------------------------------------------------------------------------------------------|
| <ul style="list-style-type: none"> 1. Steel chassis 2. Common rear flue duct 3. Heating body containing a copper finned heat exchanger 4. Electronic gas valve 5. Water flow switch 6. Gas service tap 7. Flow and return valves to isolate heating body 8. Non return valve 9. Grundfos pump 10. Patented twenty four blade | <ul style="list-style-type: none"> stainless steel multigas burner 11. Manually resettable overheat thermostat 12. Ignition and ionisation electrodes 13. Two stage thermostat 14. Built in down draught diverter 15. Reversible door, closed by two latches 16. Optional left and right hand sides panels 17. Control panel 18. Insulated water manifold allowing monotube connection 19. Waterflange PN16, 220x115mm | <ul style="list-style-type: none"> 20. Gas manifold allowing monotube connection 21. Gas flange PN10 185x77mm 22. Levelling screw 23. Electrical connections behind panel 24. Conduit for electrical cables 25. Ionisation control with manual reset 26. Draught diverter cover 27. Fuses 28. Main switches for each module with indicator lamps 29. Overheat indicator lamps |
|------------------------------------------------------------------------------------------------------------------------------------------------------------------------------------------------------------------------------------------------------------------------------------------------------------------------------------------------------------------------------------------------------------------------------|------------------------------------------------------------------------------------------------------------------------------------------------------------------------------------------------------------------------------------------------------------------------------------------------------------------------------------------------------------------------------------------------------------------------------------------------------------------------------------------------------------------------|-------------------------------------------------------------------------------------------------------------------------------------------------------------------------------------------------------------------------------------------------------------------------------------------------------------------------------------------------------------------------------------------------------------------------------------------------------------------------------|

TECHNICAL DATA

Type B11BS

Suitable only for natural gas and conversion to L.P.G.

	Moduloflame 280	Moduloflame 420
Heat input	89.5 kW	132 kW
Heat output	80 kW	120 kW
Burner manifold injectors	24	24
Minimum air supply required	337 m ³ /h	420 m ³ /h
Combustion products rate	124 g/l	145 g/l
Average flue gas temperature	71 °C	112 °C
Maximum flow temperature	90 °C	90 °C
Minimum return temperature	50 °C	50 °C
Maximum system pressure	6 bar	6 bar
Minimum system pressure	1.5 bar	1.5 bar
Water capacity	15 litres	18 litres
Electrical supply	230 V single phase - 50 Hz	230 V single phase - 50 Hz
Power consumption	300 W	500 W
Weight excluding packaging	145 kg	170 kg
Weight including packaging	183 kg	210 kg
Burner pressure G20 (natural gas) @ 20 mbar	8.8 mbar	8.8 mbar
Burner pressure G31 (propane L.P.G.) @ 37 mbar	32.8 mbar	32.8 mbar

Gas rate (15 °C -1013 mbar)			1 module	2 modules	3 modules
Gas type	Pressure	Net C.V.			
G20	20 mbar	35,9 MJ/m ³	4.65 m ³ /h	9.30 m ³ /h	13.95 m ³ /h
G31	37 mbar	46,4 MJ/kg	3.41 kg/h	6.82 kg/h	10.23 kg/h

Burner injectors

Natural gas (Restrictor diameter : \varnothing 6,4) : 1.28 mm

Propane gas (Restrictor diameter : \varnothing 6,5) : 0.74 mm

DIMENSIONS

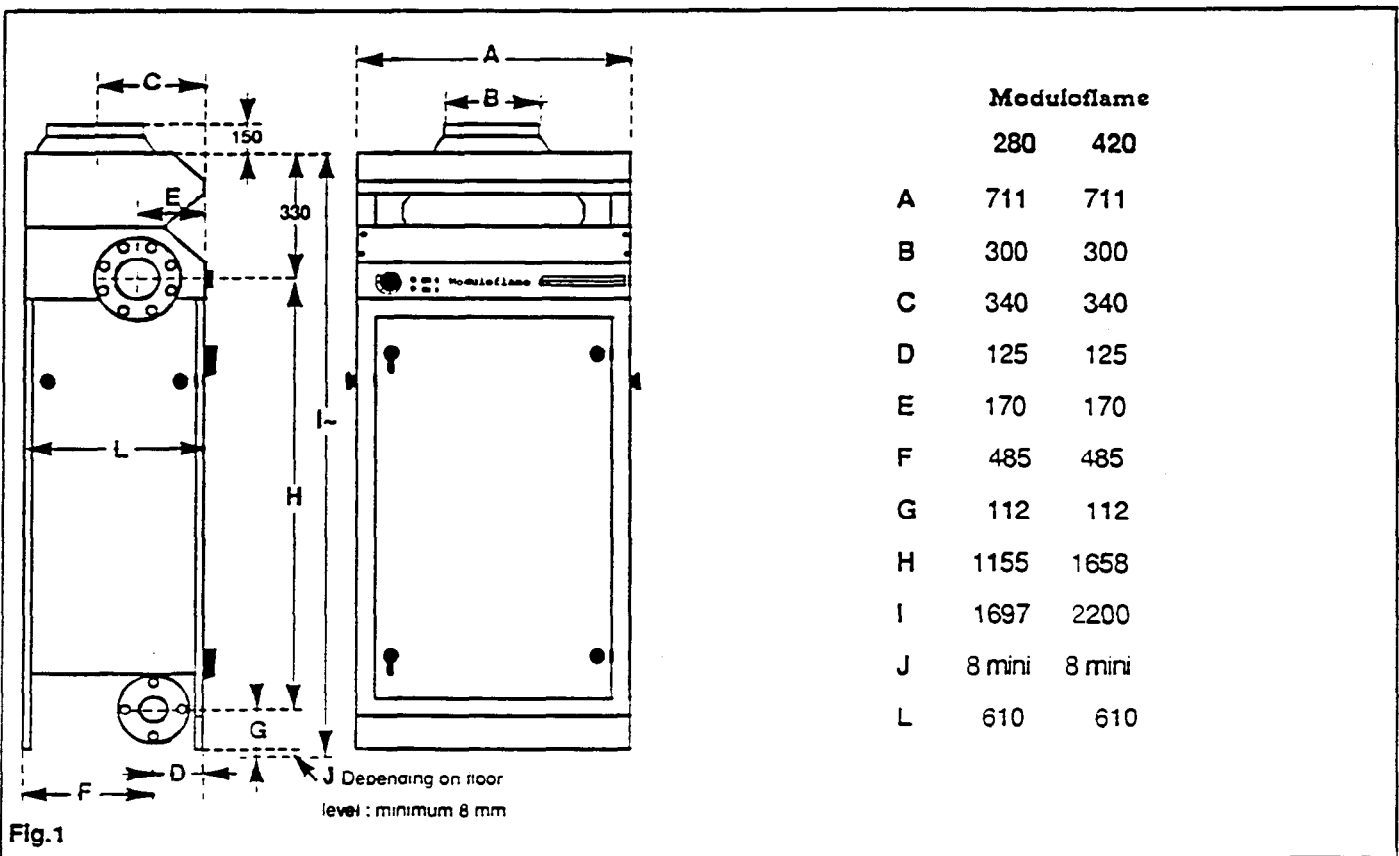

INSTALLATION & OPERATION

OPERATION

When the external controls or the boiler thermostat are calling for heat, the pump will run. When the flow switch detects the flow it will allow the ignition process to take place. The first stage of the gas valve opens and a stream of sparks ignites the gas. After 10 seconds and if the ionisation circuit has been proved, the second stage of the gas valve opens and establishes the set gas rate. The temperature is controlled by a two stage thermostat. The first stage controls the upper module and the second stage controls the lower module of the 280 and the lower two modules of the 420. At the end of a heating cycle the pump runs on for three minutes. A non return valve prevents circulation within the heating body when module is off.

SYSTEM DESIGN

The Moduloflame 280 and 420 are designed for use on installations where a high output is required with limited floor space.

The Moduloflame 280 provides the equivalent of 206.4 kW/m²

The Moduloflame 420 provides the equivalent of 304.4 kW/m²

Each module is provided with a pump to overcome the resistance of its heat exchanger. Together with the use of a

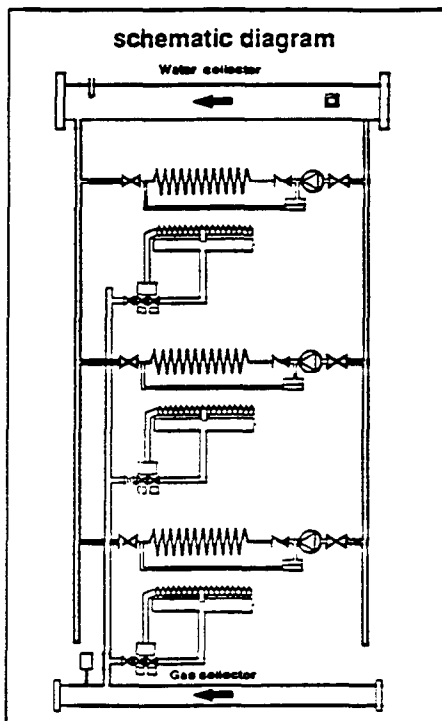

Fig. 3

monotube type water manifold obviates the need to include the boiler resistance when pump sizing. The modules are connected in parallel to a single manifold flanged at either end for simple connection to the system or to additional moduloflames.

FLOW RATES

The boiler is suitable for sealed or open systems and must only be used on indirect fully pumped systems. Particular attention must be given to achieving minimum flow rates. The nominal flow rates through the manifold must be 3m³/h for each Moduloflame 280 and 5.25m³/h for each Moduloflame 420.

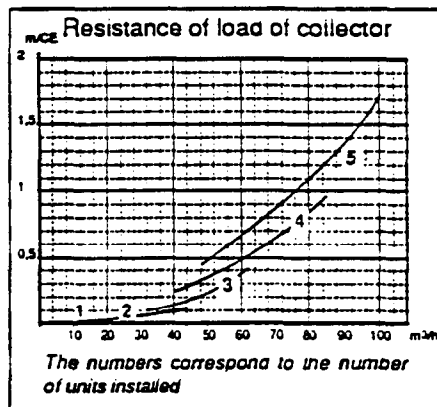

Fig.5

OPERATING PRESSURES

The system pressure water, measured at the manifold, must not be less than 1.5 bar or exceed 6 bar.

ASSEMBLY

The boilers are supplied ready assembled, covered in polythene and secured in wooden crates. The units are designed for ease of handling and to be able to pass through door ways. It is recommended that the units are stored vertically and sheltered from bad weather, particularly frost. Do not tie the boiler on its back.

Weight:

Moduloflame 280:
183 kg incl. packaging
145kg excl. packaging

Moduloflame 420:
210 kg incl. packaging
170kg excl. packaging

ACCESSORIES

Contained within the boilers

- A plastic bag containing:
1x set of installation instructions,
guarantee registration card are attached to the inside of the door.
- A carton containing
12 x 16 mm x 70 mm long bolts
12 x 16 mm nuts
4 x 16 mm x 50 mm long leveling screws (adjusted using 8 mm key)

Optional

Description:	Reference :
- Side panels kit 280	1003622
- Side panels kit 420	1003630
- Mating flanges kit	1008378
- Water / gas gasket kit	1000616

LAYOUT

The boilers may be placed side by side in order to form a single manifold. A maximum of 5 boilers can be fitted on one monotube. They can be ranged along a wall or fitted back to back in a central location. A minimum space of 0.8 metres should be allowed in front for access for maintenance.

When considering the layout, allow for the placement of the flue. Flueing can be achieved individually or grouped in ducts. Natural draught, fan assisted or fan dilution arrangements may be used. Specialist advice on flueing arrangements should be sought from flue manufacturers.

POSITIONING

A purpose made plinth is not necessary. Ensure that the floor is reasonably level and is strong enough to take the weight of the boiler(s) and ancillary controls. For multi boiler installations, check that the units are vertical and that the water and gas flange faces are parallel using the levelling screws provided. The boilers can then be bolted together using the intermediate gaskets and bolts available as accessories.

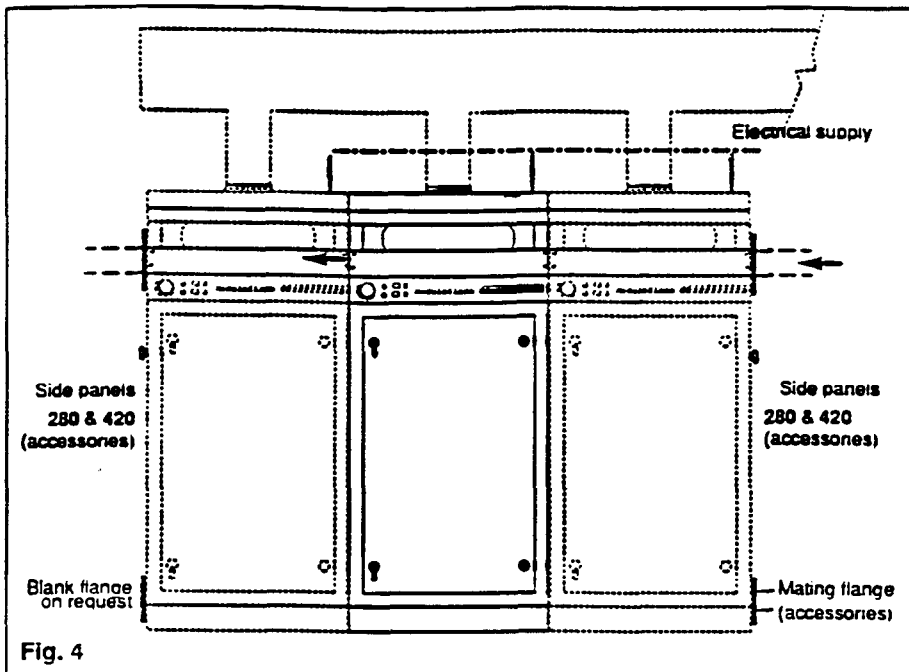

Fig. 4

CONNECTING TO THE SYSTEM

Before connecting to the system, the pipework should be chemically cleansed to remove metal filings, solder, machining oils and other fluxes and greases which might impair the performance of the boiler and its controls. Consideration should also be given to the treatment of the system water and advice can be sought from the manufacturers of water treatment products such as

Grace Dearon
Widnes
Cheshire
WA8 8UD
Tel: 0151424 5351

Fernox Manufacturing
Britannica Works
Clavering
Essex
CB11 4QZ
Tel: 01799 550811

If the boilers are being installed on an existing system, a sump and drain should be fitted on the heating return at the lowest point. It is essential that the system is fully flushed to remove any sludge and debris before the boiler is connected. Also check the flow through the system is adequate for the boiler(s): at least 3m³/h for each 280 and 5.25m³/h for each 420.

ELECTRICAL CONNECTIONS

The Moduloflame 280 and 420 boilers require a single phase 230V - 50Hz earthed electrical supply. They should be connected through a 2 Amp. fused double pole switch which should be readily accessible and adjacent to the boiler. All wiring must conform to the I.E.E. Regulations. The electrical supply is connected using the removable connector strip (Fig 8) accessible behind the upper panel (Fig 6). It is important to observe the correct polarity as reversing the connections will cause a malfunction.

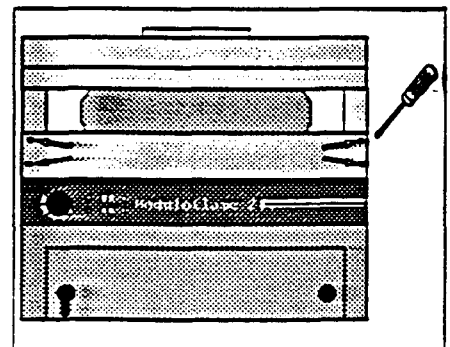

Fig. 6

CONTROLLING MODULES OR MULTIPLE BOILERS USING EXTERNAL CONTROLS

It is possible to control each module using an external management system by connecting the remote burner control cables to terminals 1, 2, 3. (Fig 8). It will also be necessary to remove the links s1 s2 s3 and making a return connection from C to the controller. To control each boiler rather than each module, a permanent live connection is made to terminal P, the link sR is removed and replaced by the boiler switching cable from the controller. In each case, terminal N is used to connect the neutrals.

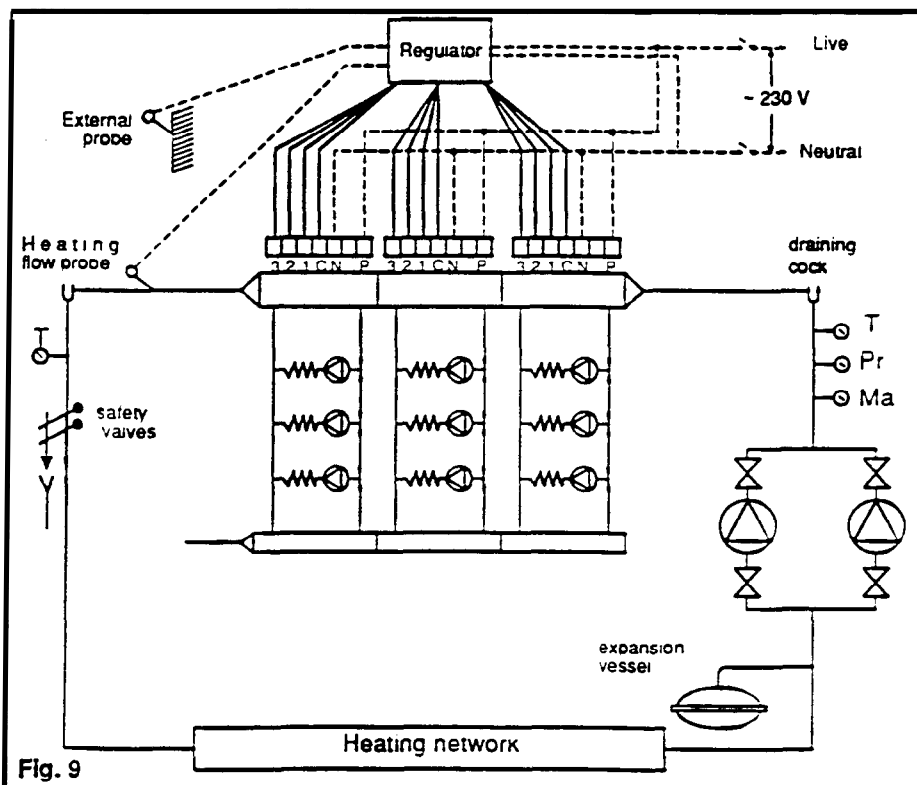

Fig. 9

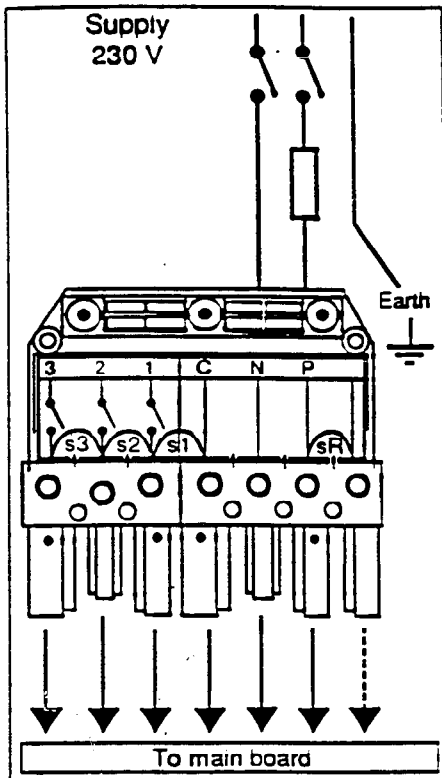

Fig. 8
COMMISSIONING

- Check that the stop valves on individual modules are fully open.
- Check electrical supply to each boiler for correct polarity and earthing continuity.
- Manually check pumps are rotating freely.

Filling and Purging

Water :

- Fill the system slowly ensuring the filling pressure remains constant.
 - Purge the installation of air.
- To purge the boilers, run pumps by switching main boiler switches to "on".

Gas :

- Open the main gas valve.
- Open the gas valves for each module.
- Ensure the main control switches are on. Attempting to light the burner will purge the gas line.

To Bring into Operation

- Ensure main power is on.
 - External controls calling for heat.
 - Boiler thermostat turned to maximum.
 - Main switches on the front panel are turned to "on".
- The pump will run and when flow is established switching the flow switch the ignition sequence will begin. The gas valve is opened and the ignitor

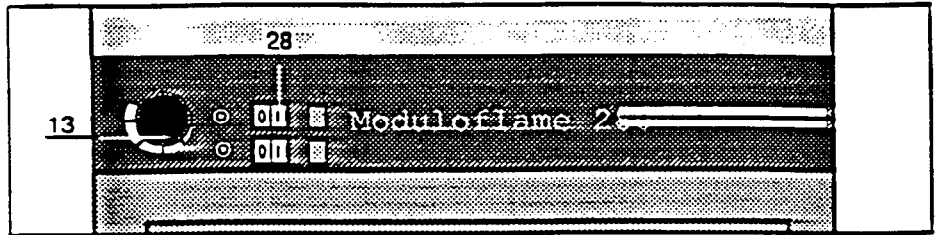

Fig. 11

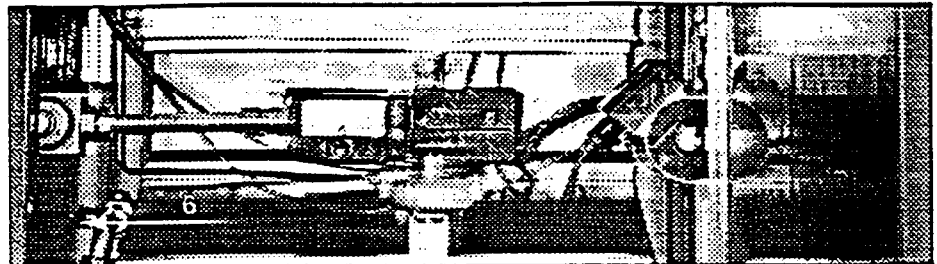

Fig. 10

runs until the flame detection device operates. If the flame is not detected within 10 seconds, the gas valve will lock out. Press the red reset button located on the front of the gas valve to restart.

Check burner pressure and ensure all connections are sound.

The burner pressure is factory set to 80% of maximum. If it is necessary, to reset then refer to the gas rate adjustment section.

- Check the correct operation of the flue. The pressure drop at the down draught diverter must be at least 5 Pa (0.5 ins w.g.)

The thermostat (fig. 11 no. 13) can be set between 28° and 85°C.

Gas Rate Adjustment

The pressure test points are located on the gas valve, to gain access to them, it is necessary to remove the electrical box from the gas valve.

Picture of the gas valve dismantled.

-To check working pressure connect a pressure gauge to test point "A" in figure XX and light the boiler. The pressure should be 20 mbar.

-To check burner pressure connect a pressure gauge to test point "B" in figure XX and light the boiler. The maximum pressure should be 8.8 mbar. For the correct pressure refer to gas rate adjustment chart.

To reset pressure:

Turn screw "C" clockwise to increase pressure and anti-clockwise to decrease whilst observing the pressure gauge.

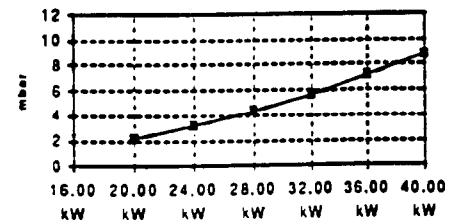

Post Commissioning

Ensure system pressure has been set correctly.
Set boiler thermostat and controls.
Set external controls.

Handing Over to the User

Demonstrate the lighting and operation of the boiler.
Explain the benefits of annual maintenance by a competent person.
Explain how to register guarantee.
Leave Installation Manual, User's Instructions and all documentation with the user.

ROUTINE SERVICING

To ensure continued efficient operation of the appliance, it is recommended that it is checked and serviced as necessary at regular intervals. The frequency of servicing will depend upon the particular installation condition and usage, but in general, once a year should be adequate.

It is the law that any service work must be carried out by a competent person such as your local Chaffoteaux Service Centre, British Gas or other CORGI registered personnel in accordance with the current Gas Safety (Installation and Use) Regulations.

The service schedule should include the following operations:

- Check the pressure in the system.
- Check the correct operation of the appliance.
- Check the correct operation of the gas controls
- Check the functions of the safety controls.
- Check combustion chamber insulation panels for damage.
- Clean the burner.
- Clean the heat exchanger.
- Check the burner manifold injectors.
- Clean gas and water filters.
- Clean and check operation of safety valve.

Additional Procedures that may be necessary:

- Carry out combustion test.
- Check, clean and replace components as necessary.
- Check burner pressure and gas flow rates.

SUGGESTED SEQUENCE for SERVICING

Before disconnecting or removing any parts, isolate the gas and electricity supplies (for detail please see section on Parts Removal and Replacement)

Preliminary Checks

- On sealed system, check the system pressure is at least 1 bar cold
- Check operation of gas valve .
- Check that the burner is extinguished fully when gas valve is closed.
- Test ionisation functions and check that lockout occurs by turning off gas tap.
- Check operation of flow switch by closing heating flow valve whilst boiler is operating.

- Check operation of boiler thermostat on each module while the boiler is at its operating temperature.

REPLACING COMPONENTS

Door

Burner manifold

Burner

Ionisation and Spark electrodes

Control PCB

Gas Valve

Drain down

Flow switch

- Isolate the module with the 2 isolating valves.

- Drain the boiler.

Pump

Main heat exchanger

Thermostat

Main PCB

Spillage detection

Fuses

Prior to any operation it is necessary to disconnect the boiler from mains, turn off the gas service tap. Before all operation on hydraulic sections, the module must be isolated and drained.

Burner

- Separate the gas section from the manifold.

- Remove the 2 fixing screws of the burner assembly located on the both side of it.

- Remove the 2 upper screws of brackets between the manifold and the front pannel of the combustion chamber.

- Pull it toward you.

Heat exchanger

- Remove the front panel of the combustion chamber.

- Unscrew the union nuts between flow and return pipes.

- Disconnect the overheat thermostat.

- Pull the exchanger toward you.

Pump

- Open the electrical box and disconnect the pump cable.

- Disconnect unions with flow and return pipes.

- Disconnect the pressure sampling pipe.

- Remove the pump clip.

- Pull the pump toward you.

Gas valve

- To remove the complete block (gas valve + electronic regulation) it is necessary to disconnect the gas valve from wiring. Remove the cover of electrical part fixed by 1 screw at the front. Unplug the cable. Then, unscrew the 2 unions and remove the complete block.

- To remove the gas valve only, unscrew the 4 screw located on both sides of the plastic part. separate the 2 blocks and let hang the electronic block. Disconnect the 2 unions on the gas pipes. Pull the gas section toward you.

Printed circuit board

- Unscrew the 4 screws of the monotube cover.

- Unplug all connections to the board and pull it from its support.

Prior to go through the flow chart, check the following items :

- System is fully vented
- All isolating taps are opened
- Gas service taps are opened

Check main voltage 230 V is available at main connector.
Ensure the correct polarity. Control that Neutral and Earth voltages are equal.

- Switch the external regulation to "ON"
- Connect S1, S2, S3 and SR as mentioned in Electrical connection chapter

Does the external regulation calling for heat or links are present into the main connector ?

No

Yes

- Rotate the thermostat knob to maximum
- Switch on the module

Check and replace if necessary the following items :

- Fuses on the PCB
- Spoilage detector
- Boiler thermostat

Does the red indicator alight on the button ?

No

Yes

Does the pump run ?

No

Yes

Does the pump energised ?

No

Yes

Check or replace if necessary the following items :

- Fuse on front panel
- Boiler PCB

Check pump spins free or replace it

Does lock out indicator alight ?

Yes

No

Press on the reset button of the gas valve

Does the ignitor run ?

No

Yes

Does the gas valve energise ?

No

Yes

- Flowswitch
- Overheat detector

Check or replace if necessary the following items :

- Ignition electrode
- Gas valve electronic block

Does the burner alight ?

No

Yes

Does the gas pressure correct at the manifold?

No

Yes

Replace the gas valve

Purge the gas line and press reset button

Does the lock out indicator alight ?

Yes

No

Check or replace if necessary the following items :

- Ionization electrode
- Electronic block of the gas valve

The boiler is in regulation phase

Heating equipment short parts list

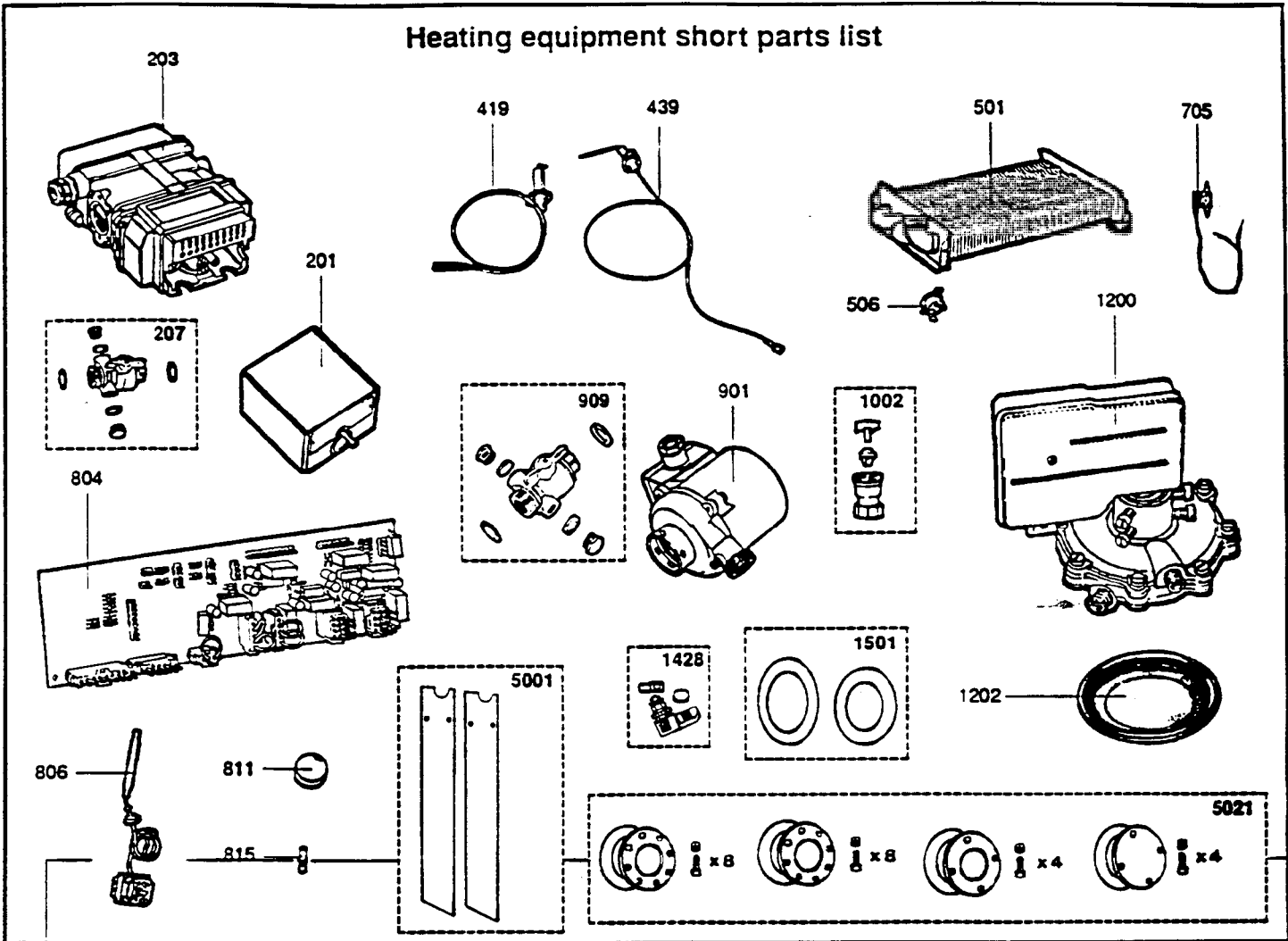

Key number :	Description :	Moduloflame 280	Moduloflame 420
201	control unit	1008250	1008250
203	gas valve assembly	1007350	1007350
207	gas service tap	81214	81214
400	2E+ burner assembly (not shown)	1002667	1002667
419	ignition electrode	36899	36899
439	ionisation electrode	75773-10	75773-10
501	heat exchanger	1007557	1007557
506	over heat sensor	1008282	1008282
705	flue spillage sensor	1003959	1003959
804	printed circuit board	1009995	1009996
806	thermostat	1009766	1009766
811	thermostat knob	1004996	1004996
815	fuses	54442	54442
901	pump assembly	1010612	1010612
909	water isolating valve	81194	81194
1002	non-return valve	54448	54448
1200	flow switch	75709	75709
1202	flow switch diaphragm	10419	10419
1428	door lock assembly	81478	81478
1501	Water and gas gasket kit	1000616	1000616
5001	Side panels kit	1003622	1003630
5021	Water and gas connection kit	1008378	1008378

Chaffoteaux et Maury are continuously improving their products and therefore reserves the right to change specifications without prior notice and accepts no liability for any errors or omission in the information contained in this document.

© Chaffoteaux et Maury 1996

Chaffoteaux et Maury Ltd
Trench Lock
Trench
Telford
Shropshire
TF1 4SZ

Tel: 01952 222727
Fax: 01952 243493

**Chaffoteaux
et Maury** 

Imp. SH - Ref. 92220-142 - 02/96